

# Instructions for Exeter Two-leaf Extension Table

Exeter two-leaf extension tables:

50" W x 72/96/112" L x 30" H

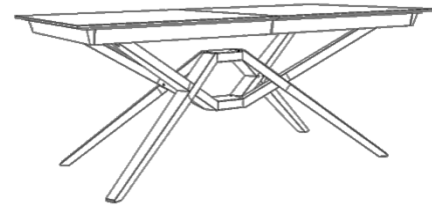

Tools required | Philips head screw driver



## Step 1: Remove the shipping blocks

Lay the *table* face down on a soft level surface. Use a Philips head screw driver to remove blocks under the *table top assembly* by detaching all the *Phillips head screws* from the *shipping blocks* (**Figure 1**). Remove any packing material underneath the table.

Phillips head screws

Shipping block

Remove the shipping blocks

Phillips head screws

Shipping block

Table top assembly

▣ **Figure 1.** Remove the *shipping blocks* from the *table top sub-assembly*

To lock the top, push down the small black handle in the middle of the slide arm. To unlock the top, simply push the handle up on both sides. *Lock-up handle* located in the middle of the *slide arm* (**Figure 3**). If you prefer to use Table Lock to operate the table top, please keep this Slide Lock unlocked at all times after initial setup of the table.

▷ **Figure 3.** Lockup handle location

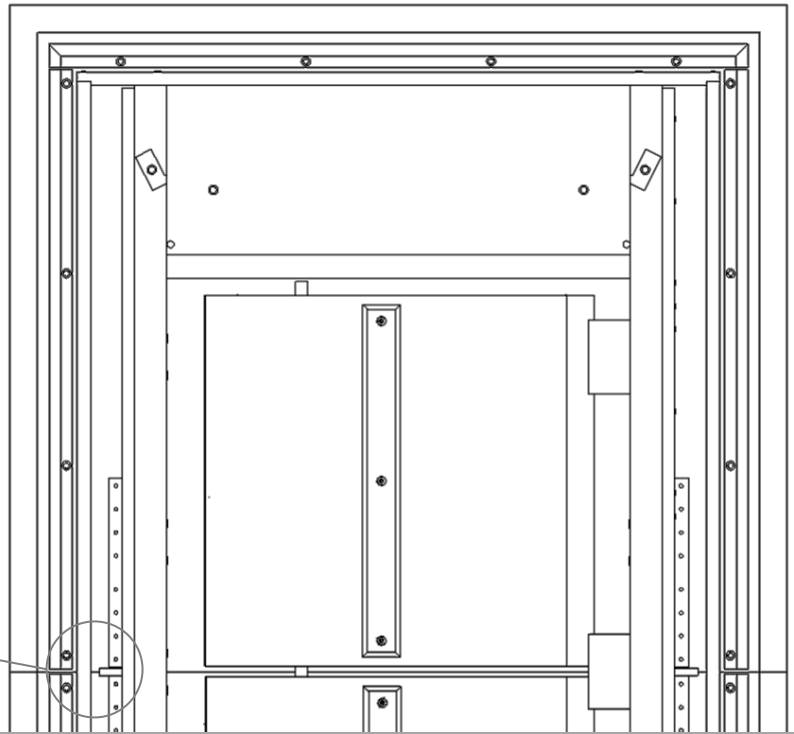
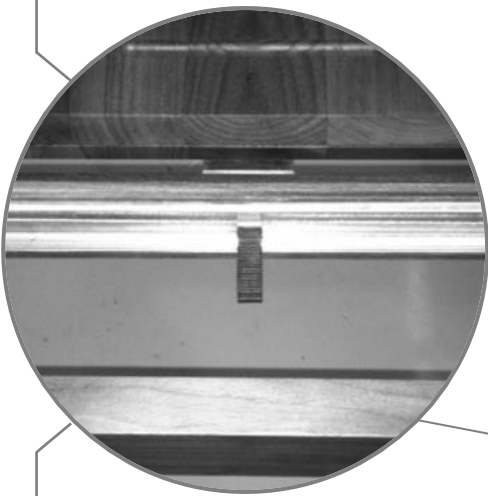

To unfold the leaves, unlock the table and open the table top (**Figure 4**). Before unfolding the leaves, make sure to move the two leaves all the way towards the left/right tops.

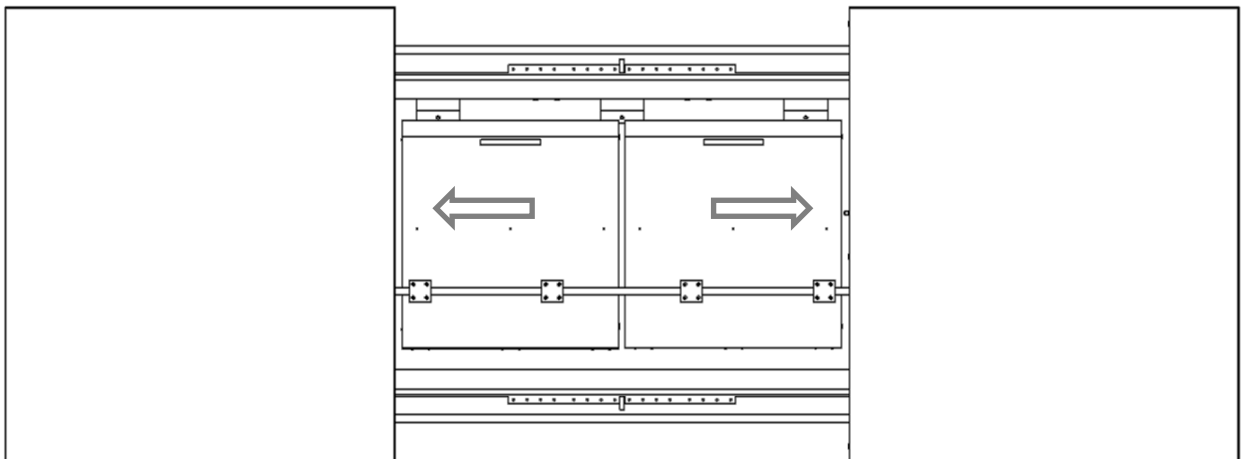

▷ **Figure 4.** Unfold the leaves

# How to Operate Extension Table Lock Mechanism



Tools required None

## Locking locations

One leaf extension tables usually have two locking locations (*Figure 1*). The inner position is for locking the table when the leaf is unfolded (*Figure 1-2*). The outer position is for locking the table when the leaf is folded (*Figure 1-1*). Two leaf extension tables have three locking locations. Similar to the one leaf table, the inner locking location is for when leaf is folded, the middle locking position is for when one leaf is open, the outer locking location is for when two leaves are open.

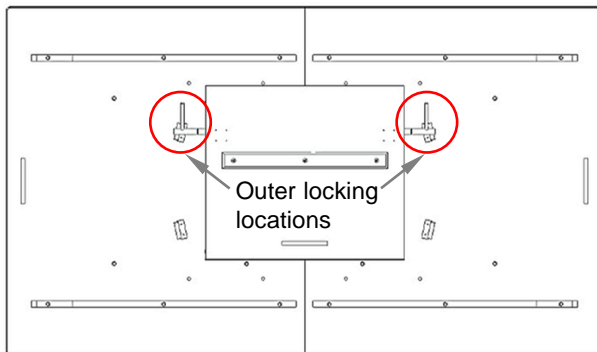

Figure 1-1. Outer locking position when leaf folded

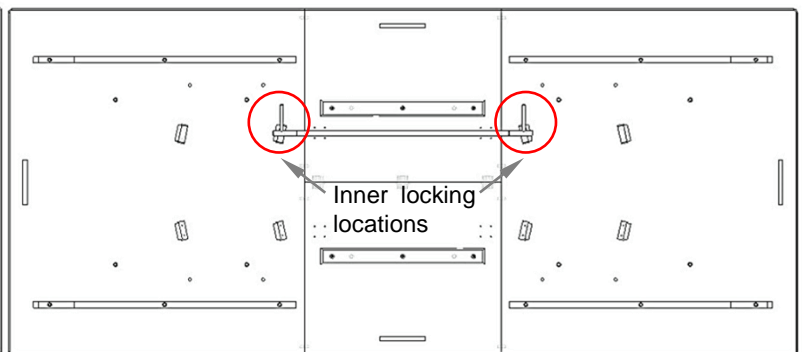

Figure 1-2. Inner locking position when leaf unfolded

## How to lock/unlock the extension table

To release the lock, simply rotate the long handle (on the underside of the table) so that the short lock pin disengages from the friction plate (*Figure 2-1*).

To lock the table, rotate the long handle on the lock mechanism till the short lock pin engages with the friction plate.

Figure 2-1. ▶  
Unlock the table

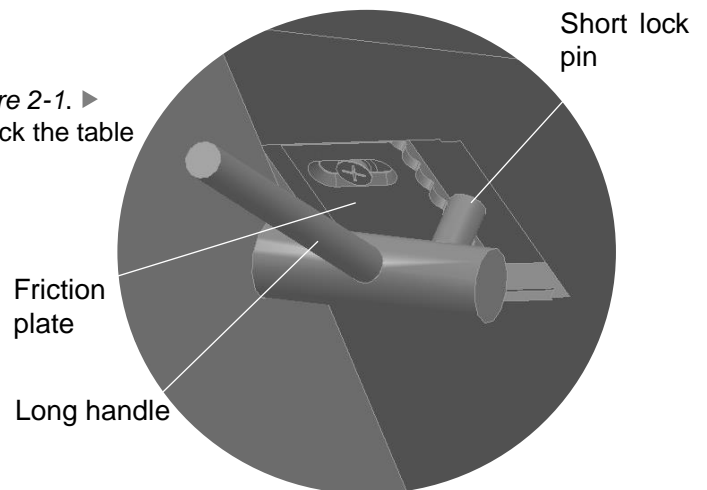

**Note:** If the lock pin is not engaging correctly, it may be necessary to adjust the friction plate. To do so, loosen the two screws on the plate, rotate the long handle so the lock pin is vertical, slide the plate forward so it touches the lock pin and re-tighten the screws. Do that at both plates for each table position (open or closed).

## Care Instructions

To care for and preserve the finish on your new Copeland Furniture piece, please keep the following recommendations in mind.

- While our furniture has been finished with a durable top coat, the surface may be sensitive to dents and abrasions during the first 30 days in your home.
- Treat the surface finish gently so it does not dent or chip. Tape or stickers should not be put on the finish.
- For general care use a soft cloth to dust the furniture.
- Use damp cloth with a mild soap to clean-up spills or dirt. Dry the surface thoroughly.
- Please do not use any polishes, waxes or solvents to clean the surface of the furniture. This holds true for new Copeland Furniture pieces as well as items you may already have in your home.
- Please do not place any candles directly on the surface of your furniture. The perfumes and dyes in the candles may penetrate the finish.
- Beds must be disassembled before moving to avoid damage. Never attempt to move the bed while it is assembled.

### Special Care Instructions for Cherry Furniture

*Please read the following if you have purchased a Copeland product in cherry.* Furniture that has been crafted from cherry wood becomes darker with age. The change in color, from a reddish tan to a reddish brown, is most noticeable during the first six months of ownership. It is important to understand that exposure to light accelerates the natural oxidization process. An object left on a cherry wood surface for an extended period of time may retard the aging process in a limited area. Simply remove the object and, over time, the surface will attain a uniform reddish brown color.

## Attention

**After the table is fully assembled, DO NOT try to pick up the table from the ends – especially if the table is fully extended. Should the table need to be relocated, close the table and carefully lift the table in the middle area where the two tops meet.**

