

LUMA™ 6761 | 6761S

LIFT DESK | STATIONARY DESK – 48 x 24 DESKTOP

USER MANUAL

LET'S GET STARTED.



DESIGN BDI DESIGN STUDIO

BDi

BDIUSA.COM

Congratulations on the purchase of your Luma desk from BDI. Your desk has been designed to provide a lifetime of enjoyment. This manual will provide assembly instructions and other helpful information to ensure you get the most out of your product. Please save it for future reference.

Your Luma has been engineered for simple assembly. Please follow these directions carefully to prevent any damage.

Should you need further assistance, contact BDI at customerservice@bdiusa.com.

ENJOY!



HARDWARE AND COMPONENTS

Unpack and identify the parts listed below. The assembly workspace should be a non-marring surface, such as carpet. For missing hardware pieces, please contact BDI Customer Service at customerservice@bdiusa.com. For all other concerns, please contact your BDI retailer.

Do not use power tools for the assembly of this product.



Hex Wrench (T1)	QTY: 1
-----------------	--------



TOOL REQUIRED (NOT INCLUDED)

Phillips Screwdriver	
----------------------	--

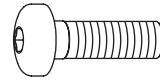

M5 x 16 Screw (H1)	QTY: 32
--------------------	---------



#6 x .5" Wood Screw (H2)	QTY: 13
--------------------------	---------

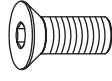

M5 x 12 Flathead Screw (H3)	QTY: 2
LIFT DESK ONLY	

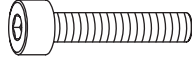

M4 x 20 Screw (H4)	QTY: 2
LIFT DESK ONLY	

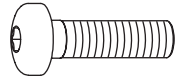

M5 x 12 Screw (H5)	QTY: 2
LIFT DESK ONLY	



Leg—Stationary or Lift (C1)	QTY: 4
-----------------------------	--------

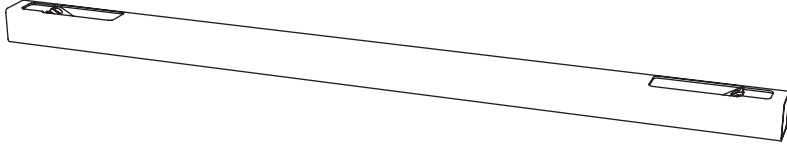

Long Frame Tube (C2)	QTY: 2
----------------------	--------



Short Frame Tube (C3)	QTY: 2
-----------------------	--------

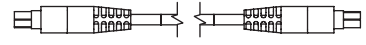

Leg Extension Cord (C4)	QTY: 4
LIFT DESK ONLY	

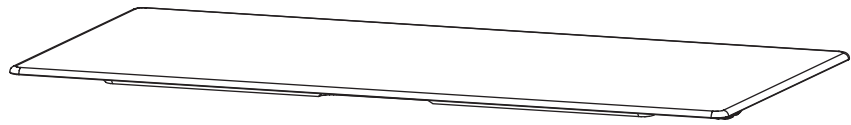

Top Panel (C5)	QTY: 1
----------------	--------

HARDWARE AND COMPONENTS



KLEET (C6)

QTY: 3

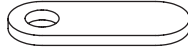

Wire Tab (C7)

QTY: 3

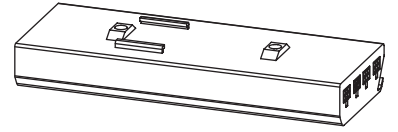

Control Module (C8)
LIFT DESK ONLY

QTY: 1

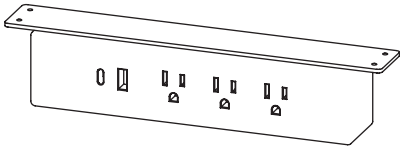

Power Strip (C9)
LIFT DESK ONLY

QTY: 1

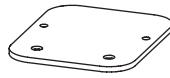

Paddle Mounting Plate (C10)
LIFT DESK ONLY

QTY: 1

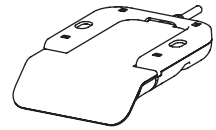

Digital Control Paddle (C11)
LIFT DESK ONLY

QTY: 1

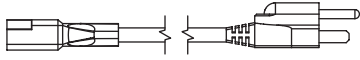

Power Cord (C12)
LIFT DESK ONLY

QTY: 1

- Lay the **Legs (C1)** as shown on a soft, non-marring surface like carpet.
- Lay the **Long Frame Tubes (C2)** with the slots facing up.
- Slide the **Long Frame Tubes (C2)** onto the **Legs (C1)**.
- Attach them using **16 Screws (H1)** and tighten with **T1**.
- Slide the **2 Short Frame Tubes (C3)** onto the **Legs (C1)**.
- Attach them using **8 Screws (H1)** and tighten with **T1**.

	HEX WRENCH – T1	QTY 1
	SCREW – H1	QTY 24

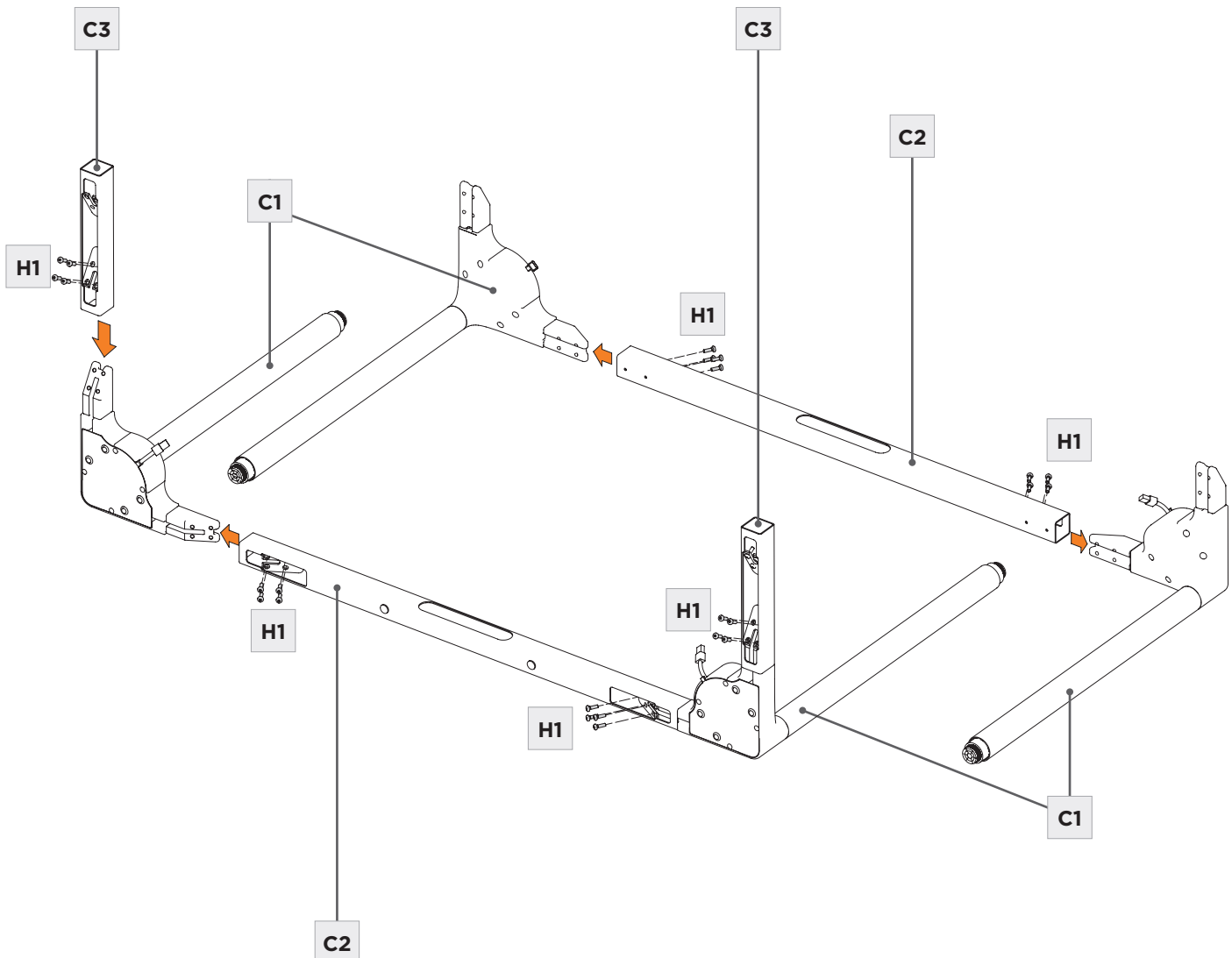

STEP 2. ATTACH SHORT TUBES TO FORM DESK FRAME

2 PERSON TASK



ASSEMBLY

With help from another person, stand both sides of the Frame upright.

- Slide the **Short Frame Tubes (C3)** onto the **Legs (C1)**.
- Insert **8 Screws (H1)** and tighten using **T1**.

	HEX WRENCH – T1	QTY 1
	SCREW – H1	QTY 8

LIFT DESK ONLY:

- Plug the **4 Leg Extension Cords (C4)** into the **4 Legs (C1)**.

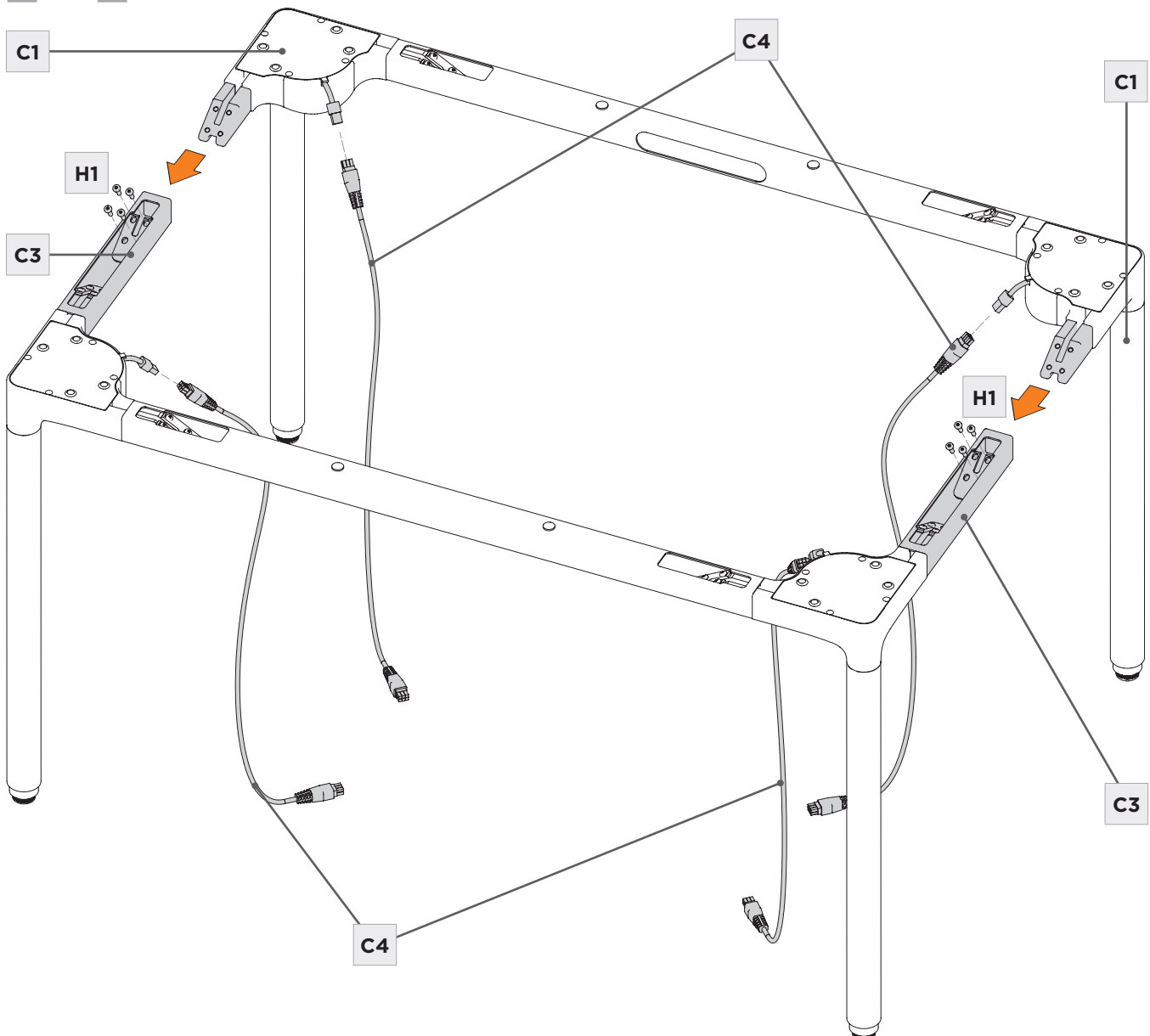
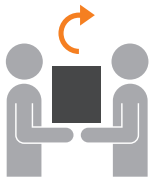

- Lay the **Top Panel (C5)** with the glass facing down on a soft surface as shown, with the front edge facing the front of the Frame.



Attach the following components using the designated screws and tools:

- **Kleets (C6):** 2 × Wood Screws (H2) per Kleet. Screw with Phillips Screwdriver.

LIFT DESK ONLY:

- **Wire Tab (C7):** 1 x Wood Screw per Tab (H2). Screw with Phillips Screwdriver.
- **Control Module (C8):** 2 × Screws (H4). Screw with Phillips Screwdriver.
- **Power Strip (C9):** 4 × Wood Screws (H2). Screw with Phillips Screwdriver.
- Attach the **3 Wire Tabs (C7)** near the groove on the same side you wish to mount your **Control Paddle** (in a later step).
- Ensure that the **Control Paddle Socket—labeled HS**—is facing the side you wish to mount your **Control Paddle** (in a later step).

Note: If you have purchased the **Luma Drawer (not included)**, now would be a good time to refer to those instructions and begin the installation process.

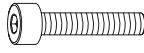
	NOT INCLUDED PHILLIPS SCREWDRIVER	QTY 1
	SCREW – H2	QTY 6–13
	HEX WRENCH – T1	QTY 1
	SCREW – H4	QTY 2



Control Module Orientation Reference

This side to face wire tabs

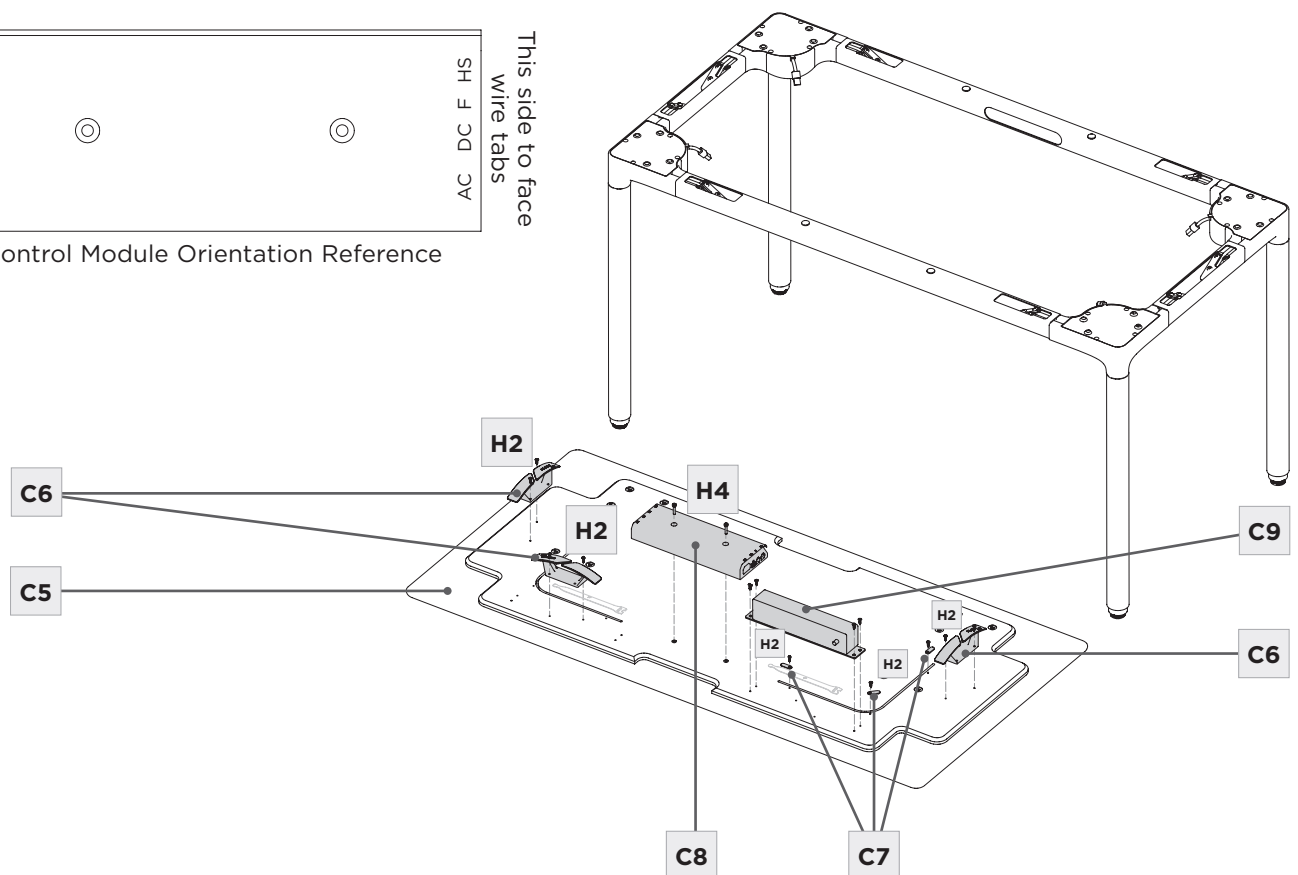

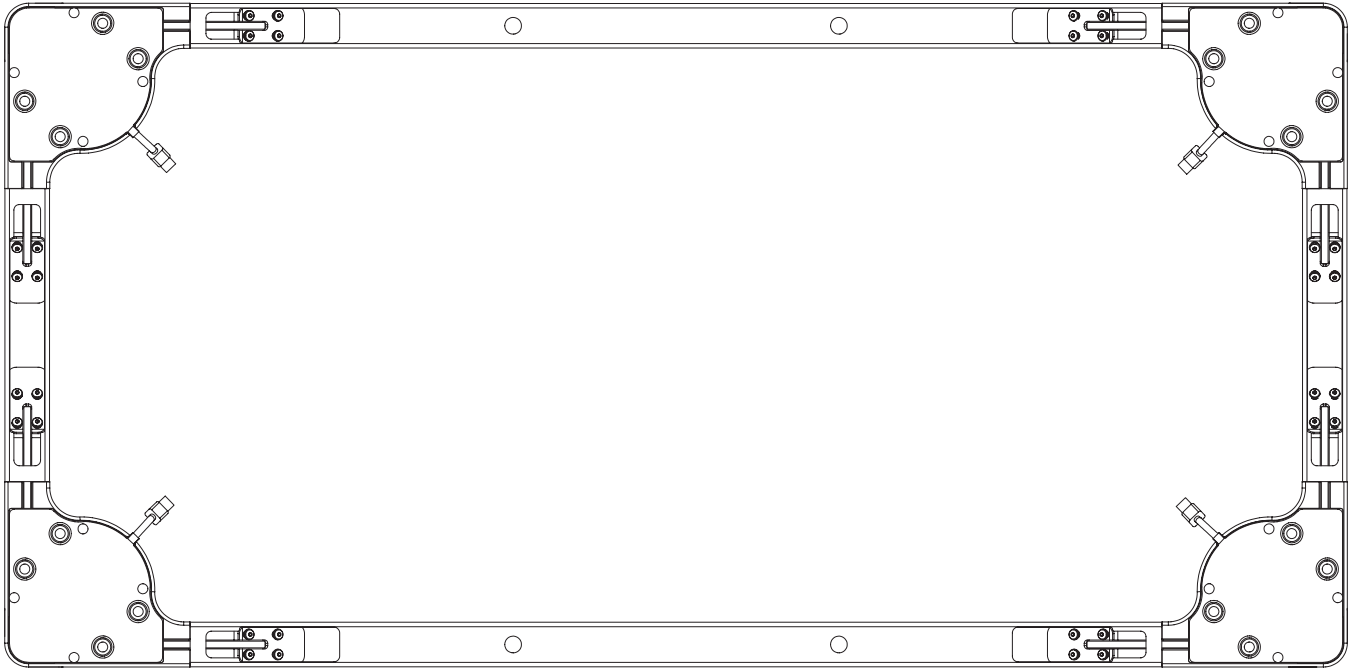

Front of Frame

Front of Top Panel

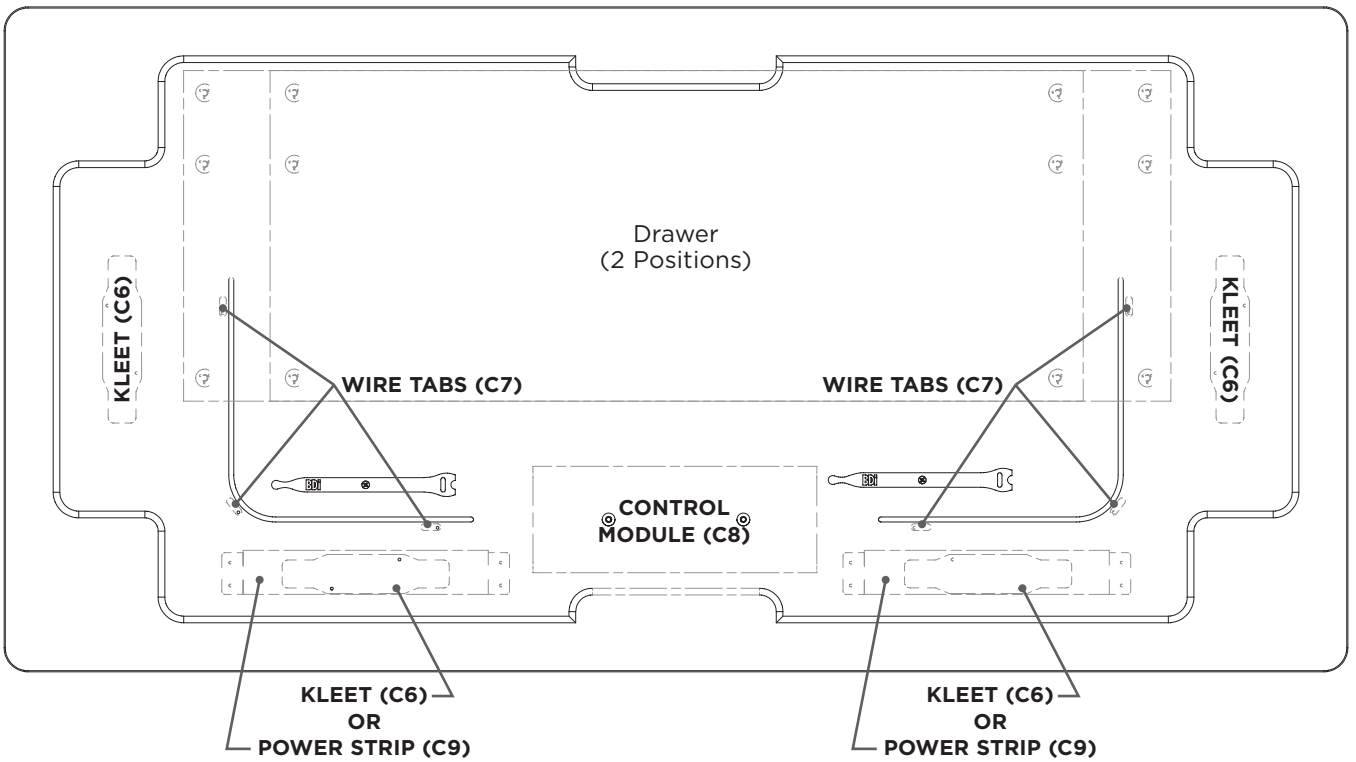

ASSEMBLY

STEP 4. PLACE TOP PANEL ONTO FRAME



With help from another person, Lift the **Top Panel** up, flip it over, and gently place it on the **Frame**.

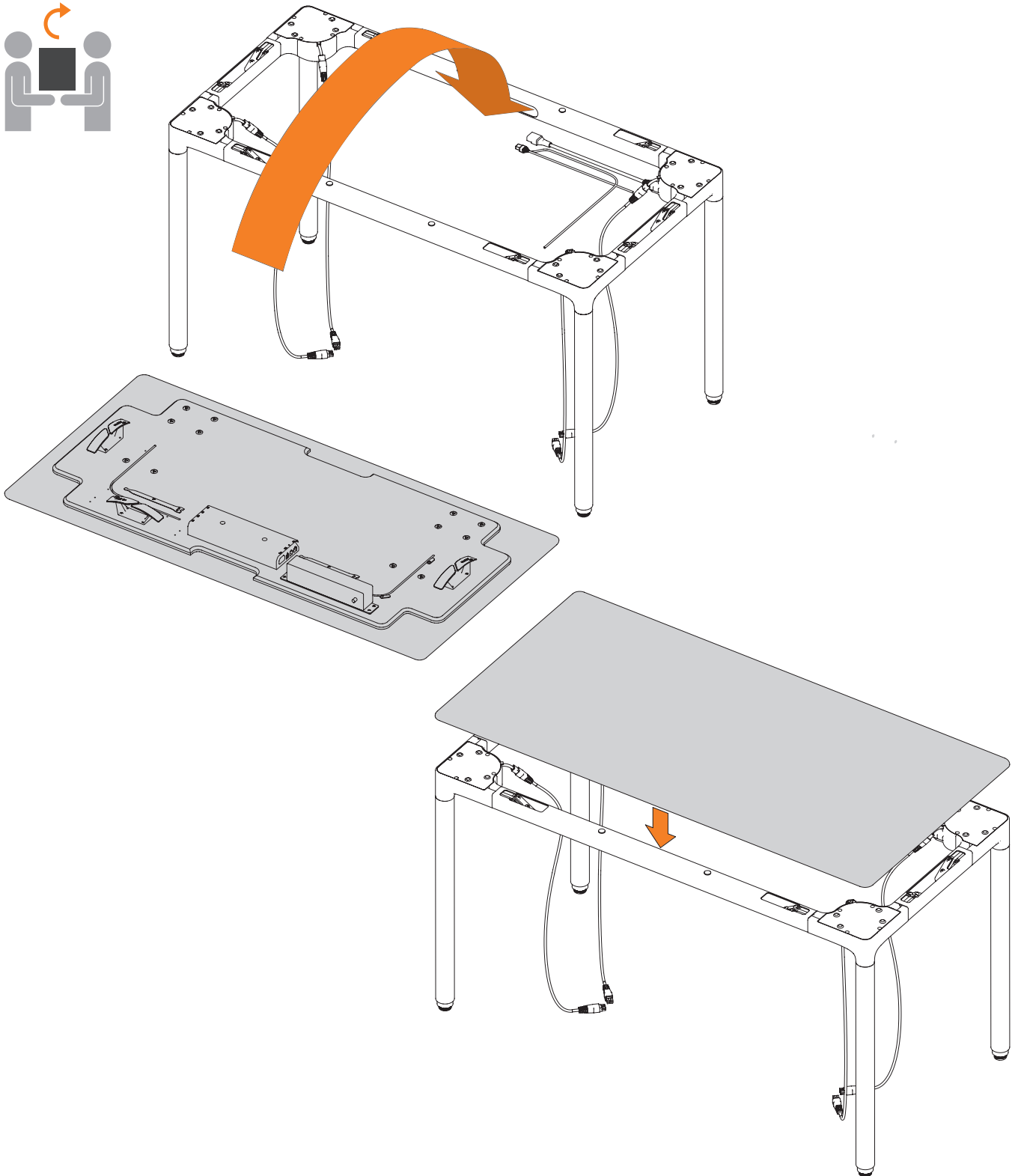
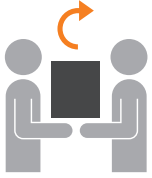



STEP 5. LIFT DESK ONLY: ATTACH CONTROL PADDLE

ASSEMBLY

LIFT DESK ONLY:

- Attach the **Paddle Mounting Plate (C10)** to the **Frame** based on how you oriented the **Control Module (C8)** in Step 3.
- Use **2 Flathead Screws (H3)** and tighten with **T1**.
- Attach the **Digital Control Paddle (C11)** to the **Mounting Plate (C10)**.
- Use **2 Screws (H5)** and tighten with **T1**.

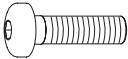
	HEX WRENCH – T1	QTY 1
	SCREW – H3	QTY 2
	SCREW – H5	QTY 2

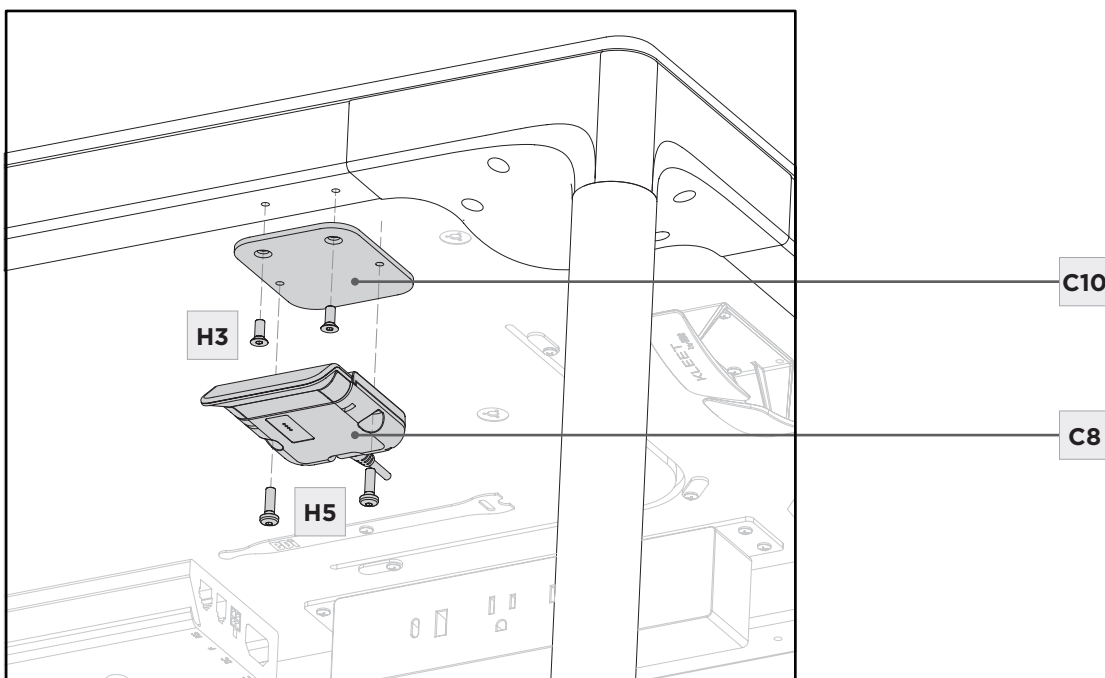
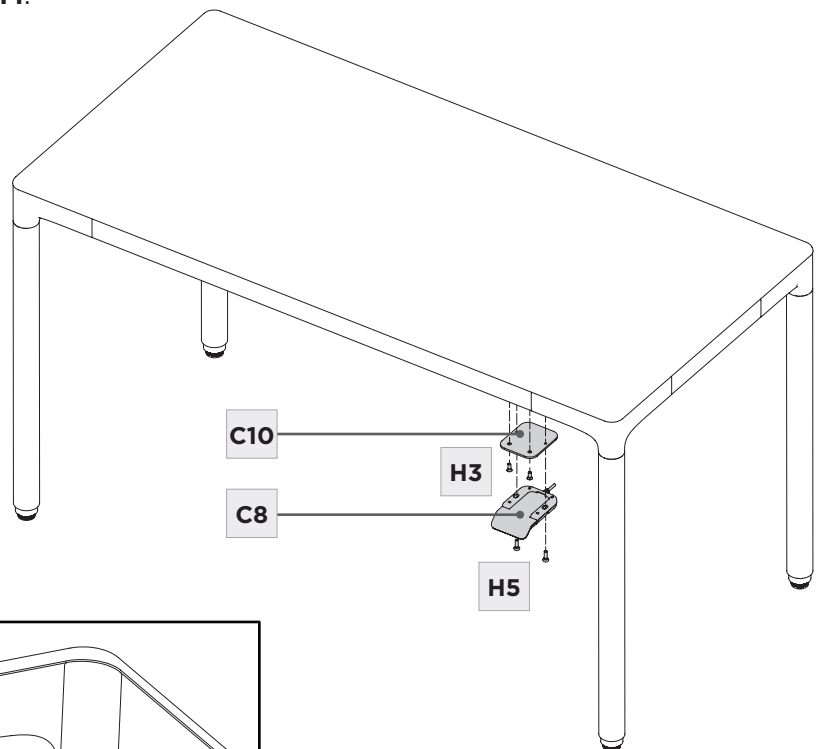

LIFT DESK ONLY:**Control Paddle Cord (C11)**

- Insert the **Control Paddle Cord (C11)** into the **groove** on the underside of the desktop.
- Plug the cord into the **HS Socket** on the **Control Module (C8)**.
- Rotate the **Wire Tabs (C7)** to secure the cord in place.

Leg Extension Cords (C4)

- Plug the **Leg Extension Cords (C4)** into **Sockets M1-M4** on the **Control Module (C8)**.
- Rotate the **Wire Tabs (C7)** to secure the cord in place.
- Plug the **Power Cord (C12)** into the **AC Socket** on the **Control Module (C8)**.
- Use **Kleets (C6)** and the included **Hook and Loop Ties** to secure loose cords.

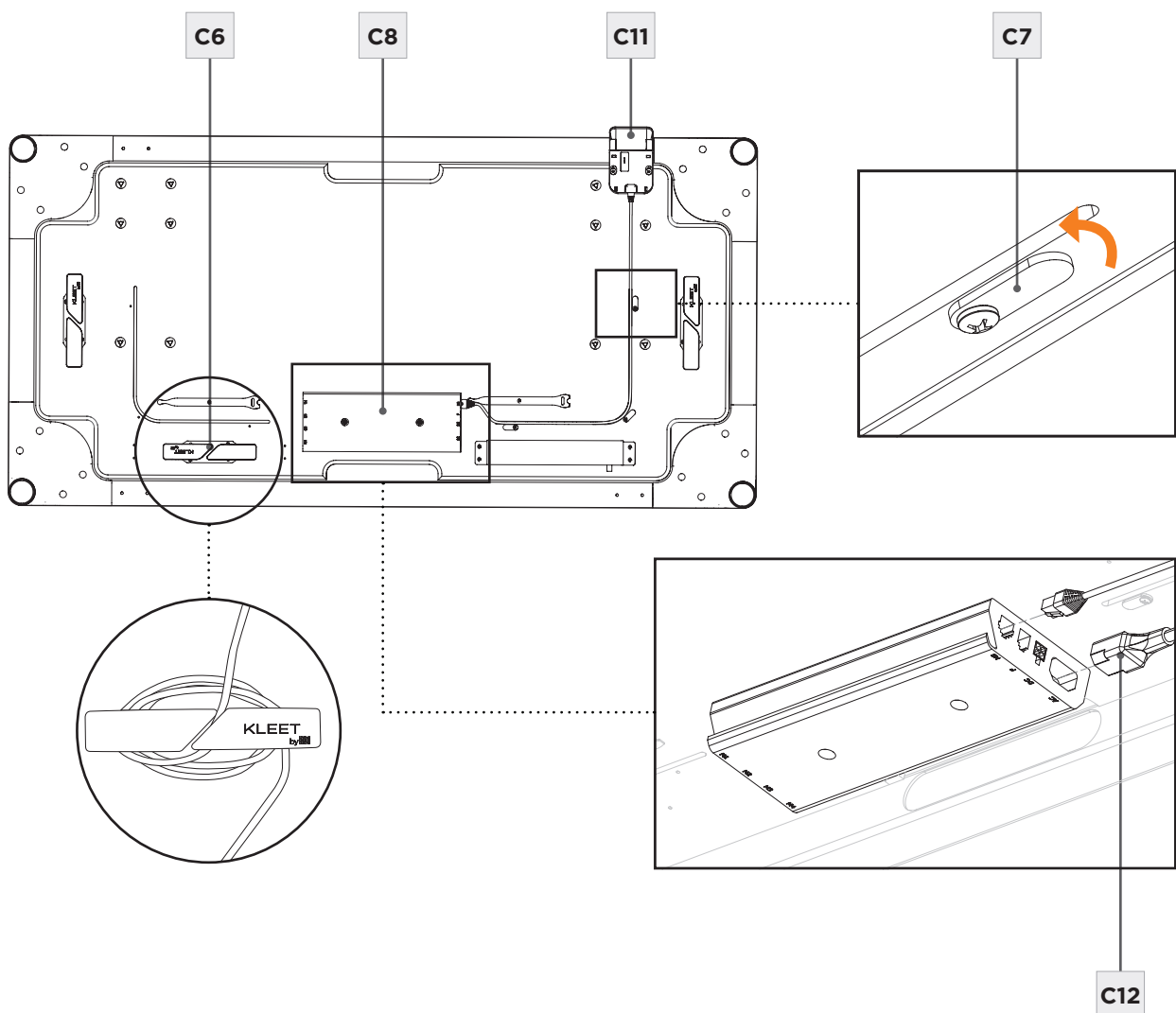

ADJUST LEVELERS

FINE TUNING

Levelers are integrated into the bottom of each leg. If your floor is uneven, you may extend one or more levelers to attain a level, stable position.

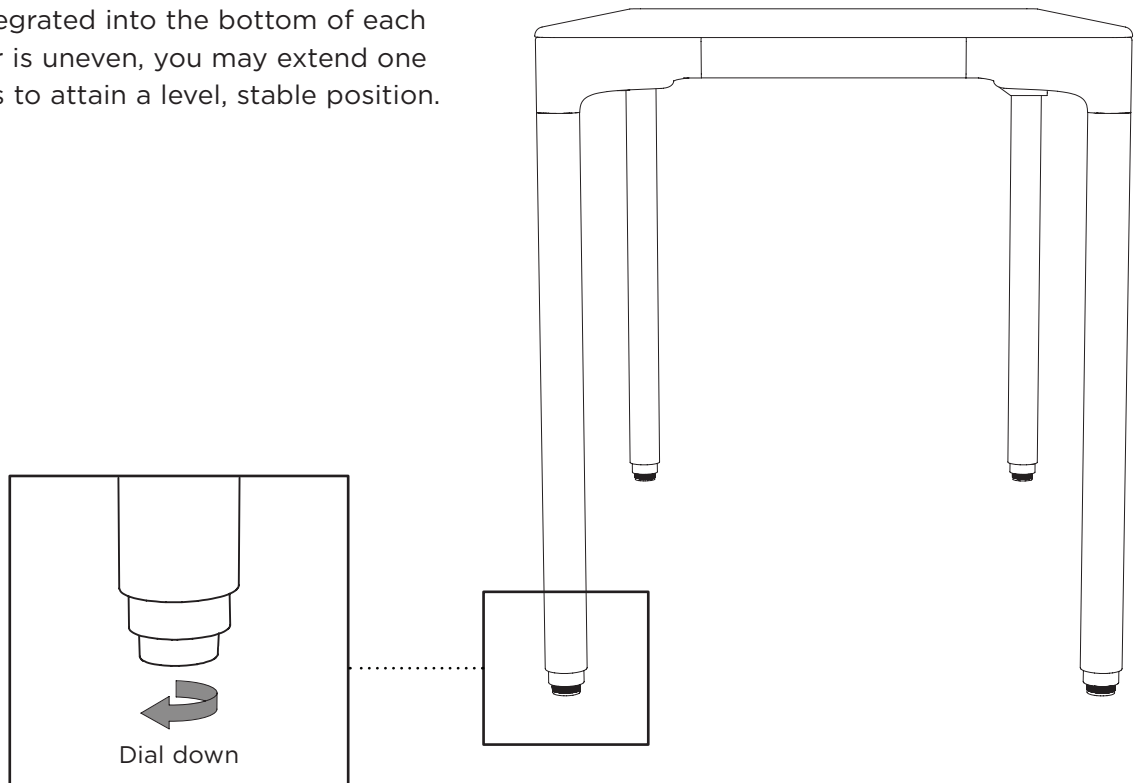

ATTACH A MONITOR ARM

FINE TUNING

The Luma Desk is compatible with most third-party monitor arms. Attach your monitor arm anywhere along the frame of the desk, ensuring the mount's clamp is resting on the flat frame tubes, and not the curved surface of the legs. Do not overtighten the monitor arm.

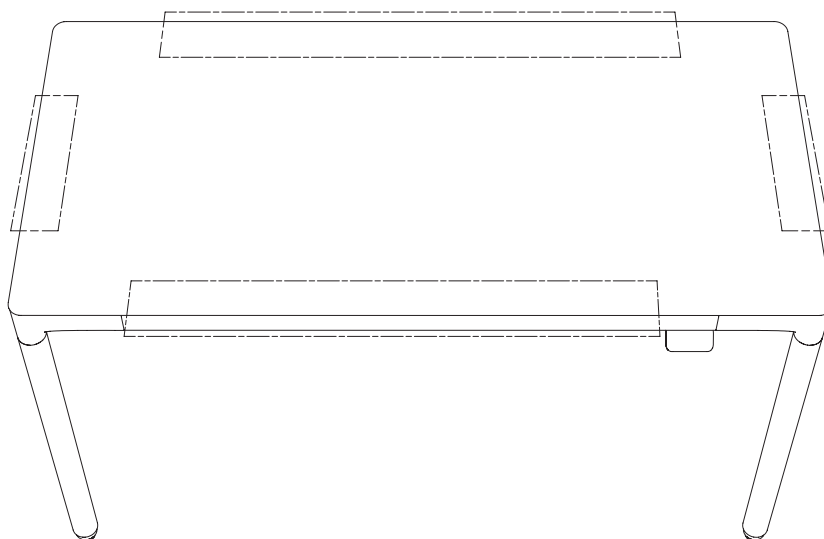

USING YOUR DIGITAL CONTROL PADDLE

Your desk's Control Paddle is designed to be intuitive and easy-to-use. Follow these steps to ensure that you are using your desk safely while getting the most out of its features.

SAFETY INFORMATION

- Ensure there are no obstructions in the desk's path (i.e. window sill, shelves)
- Position the desk slightly away from walls to avoid possible wall damage
- Be sure power cords and other wiring are long enough to reach the lowest & highest desk positions



GET TO KNOW YOUR NEW CONTROL PADDLE

The main area of the paddle is used to move your desk up or down. When programmed, a double-tap will take it to a saved seated or standing height (see below). There is a button on either side of the paddle. On the left is your Lock Button. On the right is your Menu Button that will guide you through specific user settings.



BEFORE USE: RESET YOUR CONTROL PADDLE

Resetting your control paddle calibrates the columns and control box. You can reset your control paddle at any time, it will not delete any saved height presets.

1. Press the paddle DOWN until the desk is in its lowest position. Release the paddle.
2. Press and hold the paddle DOWN again until the display reads "RESET". Release paddle. This process can take as long as 10-15 seconds.
3. Press and hold the paddle DOWN once again until the desk lowers a little more, slightly rises, then stops. Release paddle.

Your desk is now ready to use!

USING YOUR DIGITAL CONTROL PADDLE (CONTINUED)



ADJUSTING THE HEIGHT

Manually adjust the height by pressing or raising the control paddle until you achieve the desired height.

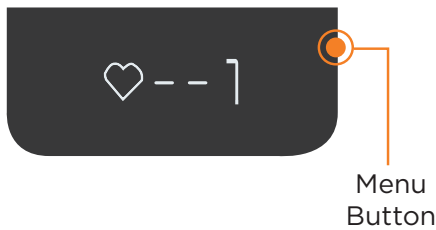

PROGRAMMING DESK HEIGHT PRESETS

1. To program your favorite seated and standing position, start by using the paddle to position the desktop to the desired height.
2. Press the right side menu button two times. A heart and a 1 or 2 will appear, signifying that your position has been set. 1 = seated position; 2 = standing position.

MOVING THE DESKTOP TO A SAVED HEIGHT

1. Tap the paddle to awaken it.
2. Double-tap up or down to move the desktop to the programmed height.



LOCKING CONTROL PADDLE

Press and hold the left side lock button until the display shows a lock symbol, approximately four seconds.

Repeat this step to unlock.

USING YOUR DIGITAL CONTROL PADDLE (CONTINUED)

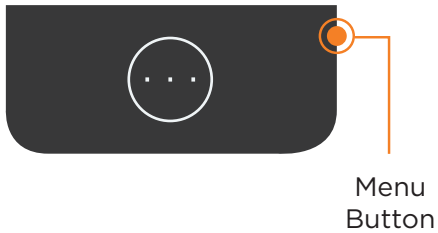

ADVANCED USER SETTINGS

For further optional customizations, you will need to access the Settings Menu. To access this menu, press and hold the Menu Button for approximately five seconds. Your settings options will appear. You can scroll through four menu screens by pressing the paddle.



SETTING THE MINIMUM OR MAXIMUM DESK HEIGHT

If you need to limit the range of movement of your desktop, this can be set using the first menu item.

1. Position your desktop at the height where you would like to stop your desk.
2. Hold the **Menu Button** for five seconds until the **Settings Menu** appears.
3. Press the **Menu Button** again, selecting menu 1 of 4, ↑↓.
4. Use the paddle to move through the presented options:
 - MIN** Saves current desktop height as the minimum that the desk will not go below
 - MAX** Saves current desktop height as the maximum that the desk will not go above
 - OFF** Removes any programmed minimum or maximum positions
 - ↶ Returns you to the main menu
5. Press the **Menu Button** again to program your selection.

USING YOUR DIGITAL CONTROL PADDLE (CONTINUED)



CHANGING YOUR DISPLAY FROM INCHES TO CENTIMETERS

If you would prefer to see your display in metric dimensions, you can change this setting while your desk is in **Reset Mode**.

1. Press the paddle DOWN until the desk is in its lowest position. Release the paddle.
2. Press and hold the paddle DOWN again until the display reads **RESET**. Release paddle.
3. While the paddle says RESET, press the **Menu Button** to access the **Settings Menu**.
4. Use the paddle to cycle through options, pressing the **Menu Button** again to access the **in ↔ cm** settings.
5. Use the paddle to select IN (inches), CM (centimeters) or ← to return you to the main menu.
6. Press the **Menu Button** again to program your selection.
7. Press and hold the paddle DOWN once more until the desk lowers slightly, slightly rises, then stops. You have now exited Reset Mode.



ADJUSTING COLLISION SENSITIVITY ON YOUR DESKTOP

Your desktop includes a built-in collision sensor, stopping your desk automatically if anything comes in contact with it while in motion. By default, your desk is set to MEDIUM sensitivity. You can change this setting while your desk is in **Reset Mode**.

1. Press the paddle DOWN until the desk is in its lowest position. Release the paddle.
2. Press and hold the paddle DOWN again until the display reads **RESET**. Release paddle.
3. While the paddle says RESET, press and hold the **Menu Button** for five seconds to access the **Settings Menu**.
4. Use the paddle to cycle through options, pressing the **Menu Button** again to access the **Collision Sensitivity** settings.
5. Use the paddle to cycle through LOW, MEDIUM and HIGH to select the level of sensitivity desired.
6. Press the **Menu Button** again to program your selection. This can take up to 15 seconds to reprogram.
7. Press and hold the paddle DOWN once more until the desk lowers slightly, slightly rises, then stops. You have now exited Reset Mode.

For more information, detailed specifications, and online assistance, visit www.bdiusa.com/luma

CARE & MAINTENANCE

Your BDI furniture has been constructed with the finest materials, carefully manufactured, and designed to last a lifetime. Regular furniture care will prolong your enjoyment and keep it looking its best. Here are some general tips for taking care of BDI furniture. Your surfaces may vary.

GLASS

Glass surfaces are maintained using household glass cleaner and a paper towel or cloth.

SATIN-ETCHED GLASS

This uniquely smooth-to-the-touch glass surface can be regularly maintained using household glass cleaner and a paper towel or cloth.

A 'Magic Eraser' removes minor scratches or scuffs not eliminated using a paper towel or cloth. 'Magic Eraser' is a melamine foam product available at any grocery store or home improvement center. Dampen the entire glass surface and the Magic Eraser, then rub the whole surface in broad, even strokes using moderate pressure. Clean and dry the surface with a paper towel. Check for results and repeat as necessary. Any scratches or scuffing not eliminated by one of the above methods can often be addressed by 'refreshing' the glass. This process should not be required more than once per 6-12 months. See this brief video for the simple method: www.bdiusa.com/glass

WOOD

Wood surfaces should be cleaned with a slightly damp (not saturated) cloth or paper towel. Do not use glass cleaner on wood. If moisture remains, dry the surface with another cloth. If needed, a gentle, non-abrasive cleanser may be used, but wipe away all cleaner residue and dry the surface with a cloth.

BDI's wood finishes feature natural hardwood solids and veneers. Wood is a product of nature and—unlike man-made materials that can be manufactured to strict and consistent specifications—has natural imperfections that are part of its appeal and character. Every piece of wood differs from every other, even when coming from the very same tree. As such, grain, texture, and tone variation should be expected from one panel or piece of furniture to the next.

While BDI's stained wood finishes are stable in tone & appearance, all finishes are subject to some degree of discoloration with prolonged exposure to direct sunlight. Please avoid positioning your BDI cabinet in any area with ample direct sunlight. To learn more about the features of natural wood, visit www.bdiusa.com/wood

METAL, PORCELAIN, & PAINTED SURFACES

Surfaces should be cleaned with a slightly damp (not saturated) cloth or paper towel. If moisture remains, dry the surface with another cloth. If needed, a gentle, non-abrasive cleanser may be used, but be sure to wipe away all cleaner residue and dry the surface with a cloth.

WARRANTY

BDI warrants to the original purchaser that for the below-stated warranty term, BDI will replace any product, part, or component covered by this warranty that fails under normal use as a result of a defect in material or workmanship. The decision to replace a complete product versus the part or component in question will be at BDI's sole discretion.

Residential Use: BDI Furnishings carry warranty coverage for three (3) years from the date of product delivery, as shown on your sales receipt/documentation. Select chairs carry coverage for five (5) years from the date of product delivery.

Commercial Use: BDI Furnishings carry warranty coverage for one (1) year from the date of product delivery, as shown on your sales receipt/documentation. Select chairs carry coverage for five (5) years from the date of the product delivery, based on an 8-hour daily use pattern.

BDI reserves the right to refine or update its warranty from time to time. See the complete and latest warranty document at www.bdiusa.com/warranty.

PRODUCT REGISTRATION

Registering your new BDI product allows us to send you important product updates, service information, and helpful hints related to your BDI products.

Register today, and you will be **entered to win free a BINK table** from BDI: www.bdiusa.com/register

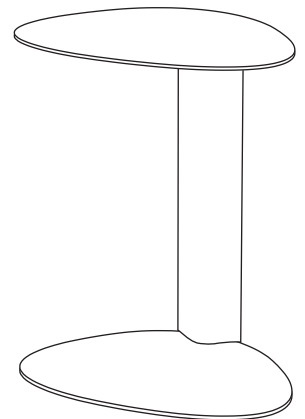



BDIUSA.COM

These distinctive product configurations are protected by US and international patents, trade dress, and/or copyright laws. Luma & BDI are trademarks of Becker Designed, Inc. All rights reserved.
©2025, BDI | V.07.14.2025