

CODA™ 3521/3522

OFFICE CHAIR

INSTRUCTION MANUAL

LET'S GET STARTED.

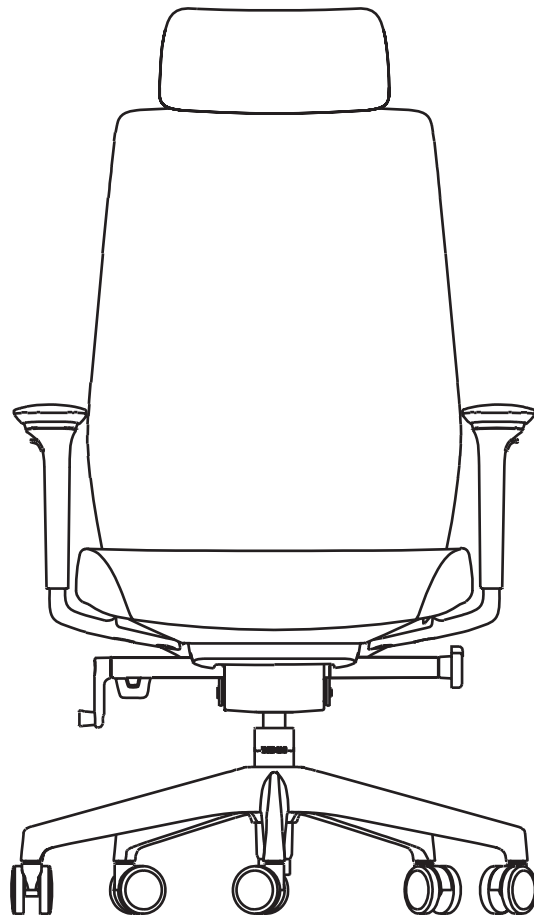

DESIGNED BY CLAUDIO BELLINI

BDi

BDIUSA.COM



Congratulations on the purchase of your Coda Office Chair 3521/3522 from BDI. Your office chair has been designed to provide a lifetime of enjoyment. This manual will provide you with assembly instructions and other helpful information to ensure you get the most out of your product. Please save it for future reference.

Your Coda Office Chair has been engineered for simple assembly. Please follow these directions carefully to prevent any damage.

Should you need further assistance, contact BDI at customerservice@bdiusa.com.

ENJOY!

HARDWARE AND COMPONENTS

Unpack and identify the parts listed below. The assembly workspace should be a non-marring surface such as carpet. For missing hardware pieces, please contact BDI Customer Service at customerservice@bdiusa.com.

Do not use power tools for the assembly of this product.

For all other concerns, please contact your BDI retailer.

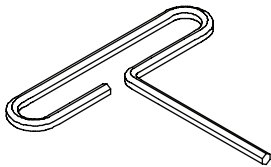

5mm Hex Wrench (T1)

QTY: 1



4mm Hex Wrench (T2)

QTY: 1

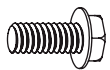

Hex Screw w/ Washer (H1)

QTY: 3

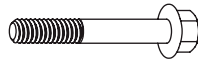

Hex Screw x 2 1/4" (H2)

QTY: 6

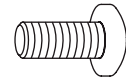

Pan Head Screw x 1/2" (H3)

QTY: 2

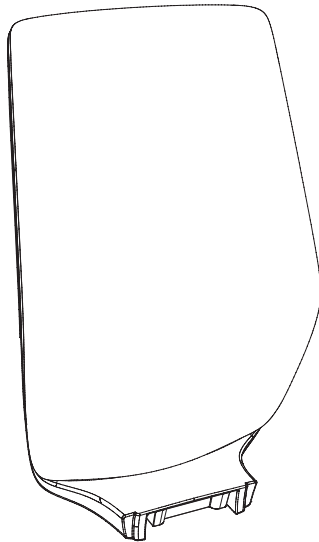

Backrest Assembly (C1)

QTY: 1

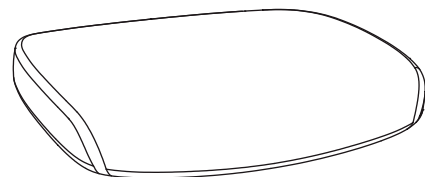

Seat Assembly (C2)

QTY: 1

HARDWARE AND COMPONENTS

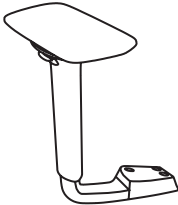

Armrest (Left & Right) (C3)

QTY: 1 of each



Lift Column (C4)

QTY: 1

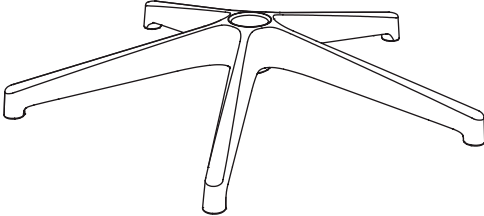

Base (C5)

QTY: 1

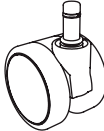

Wheel (C6)

QTY: 5

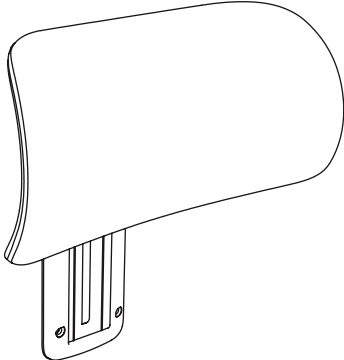

Headrest (C7)

QTY: 1

Using the box as a workbench, position the **Seat Assembly (C2)** as shown. Lift and pull the **Backrest Assembly (C1)** toward the **Seat Assembly (C2)** so the mounting holes align. Fasten using **3 Screws with Washers (H1)**. Tighten with **5mm Hex Wrench (T1)**.

	HEX WRENCH – T1	QTY 1
	SCREW – H1	QTY 3

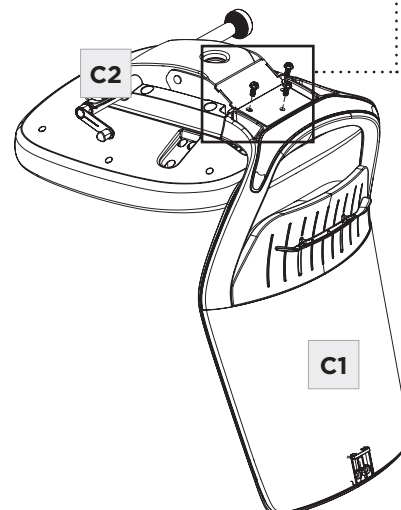
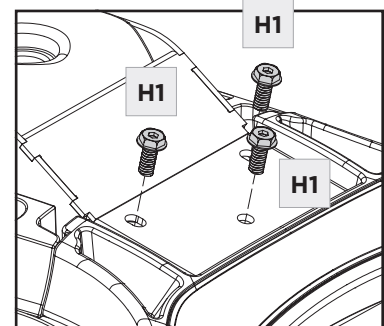
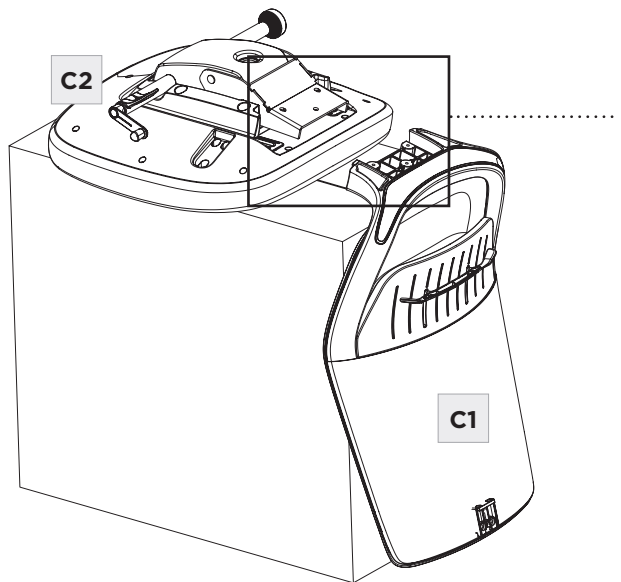
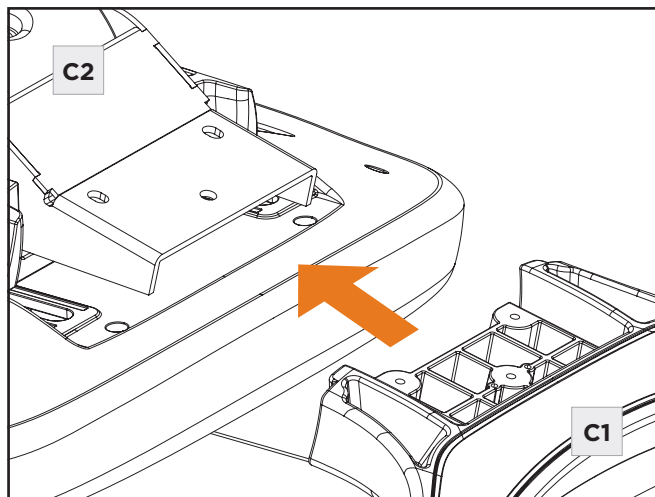

STEP 2. ATTACH ARMREST

ASSEMBLY

Ensuring the R and L labels on the **Left and Right Armrests (C3)** match the R and L labels on the **Seat Assembly (C2)**, attach the armrests to the seat using **6 Screws (H2)** and tighten with **5mm Hex Wrench (T1)**.

	HEX WRENCH – T1	QTY 1
	SCREW – H2	QTY 6

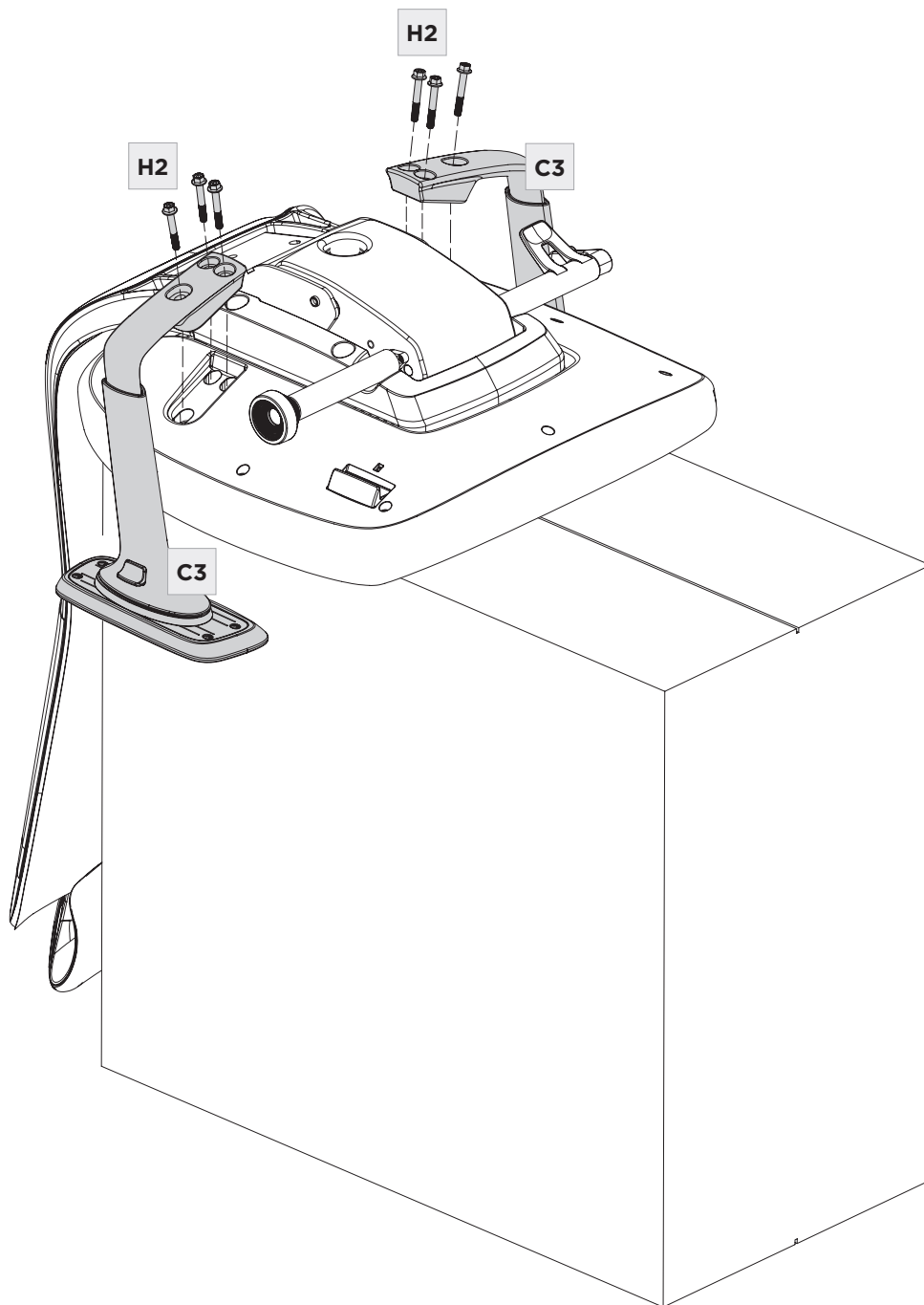

ASSEMBLY

STEP 3. INSTALL LIFT COLUMN

Position the **Lift Column's (C4)** narrow end into the hole on the bottom of the **Seat Assembly (C2)**. Press into place.

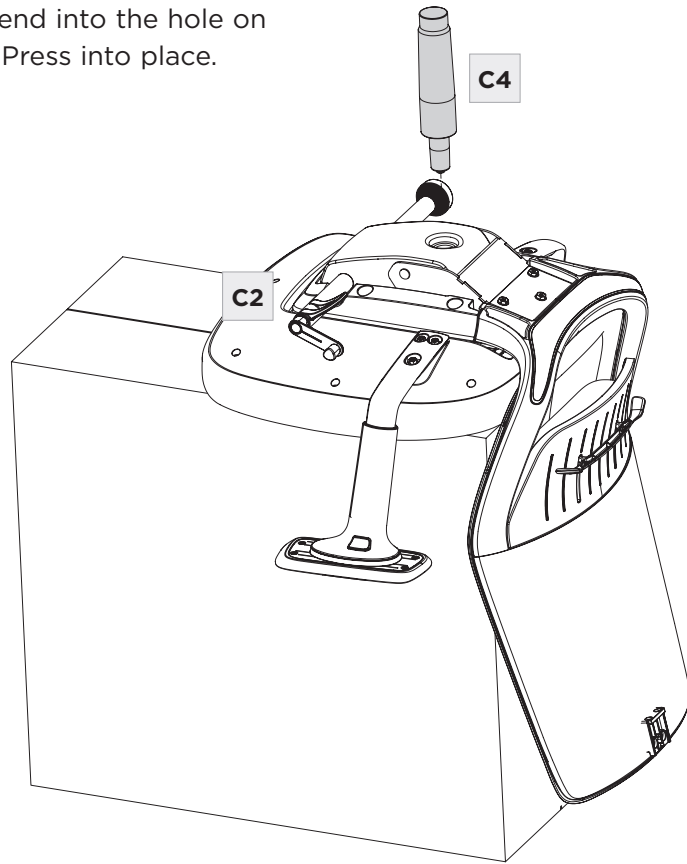

ASSEMBLY

STEP 4. INSTALL SWIVEL WHEELS

Position the **Base (C5)** upside down on the carpeted floor. Press the **Swivel Wheels (C6)** firmly into the holes until they lock.

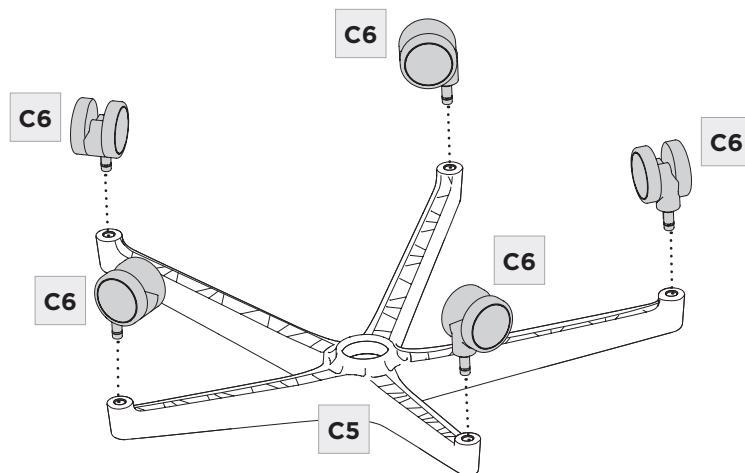



STEP 5. CONNECT THE BASE

ASSEMBLY

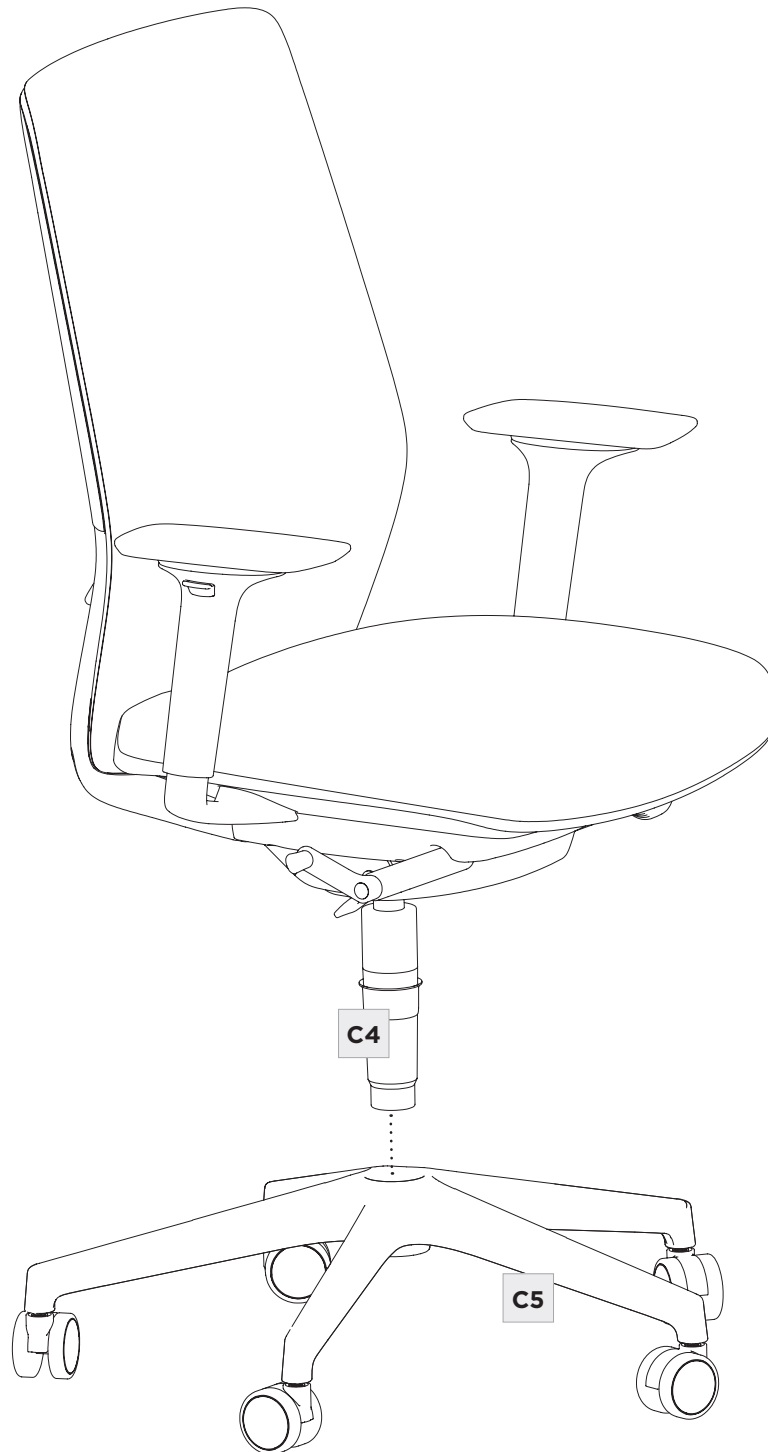
Connect the **Base (C5)** to the chair either right side up (with base on the floor as shown) or upside down on top of the box. Insert the **Column (C4)** into the hole and press to fit.



Attach the **Headrest (C7)** to the back of the chair by inserting **2 Pan Head Screws x 1/2" (H3)** from the bottom. This is easiest to do if the Headrest is in its highest position. Tighten with **4mm Hex Wrench (T2)**.

	HEX WRENCH – T2	QTY 1
	SCREW – H3	QTY 2

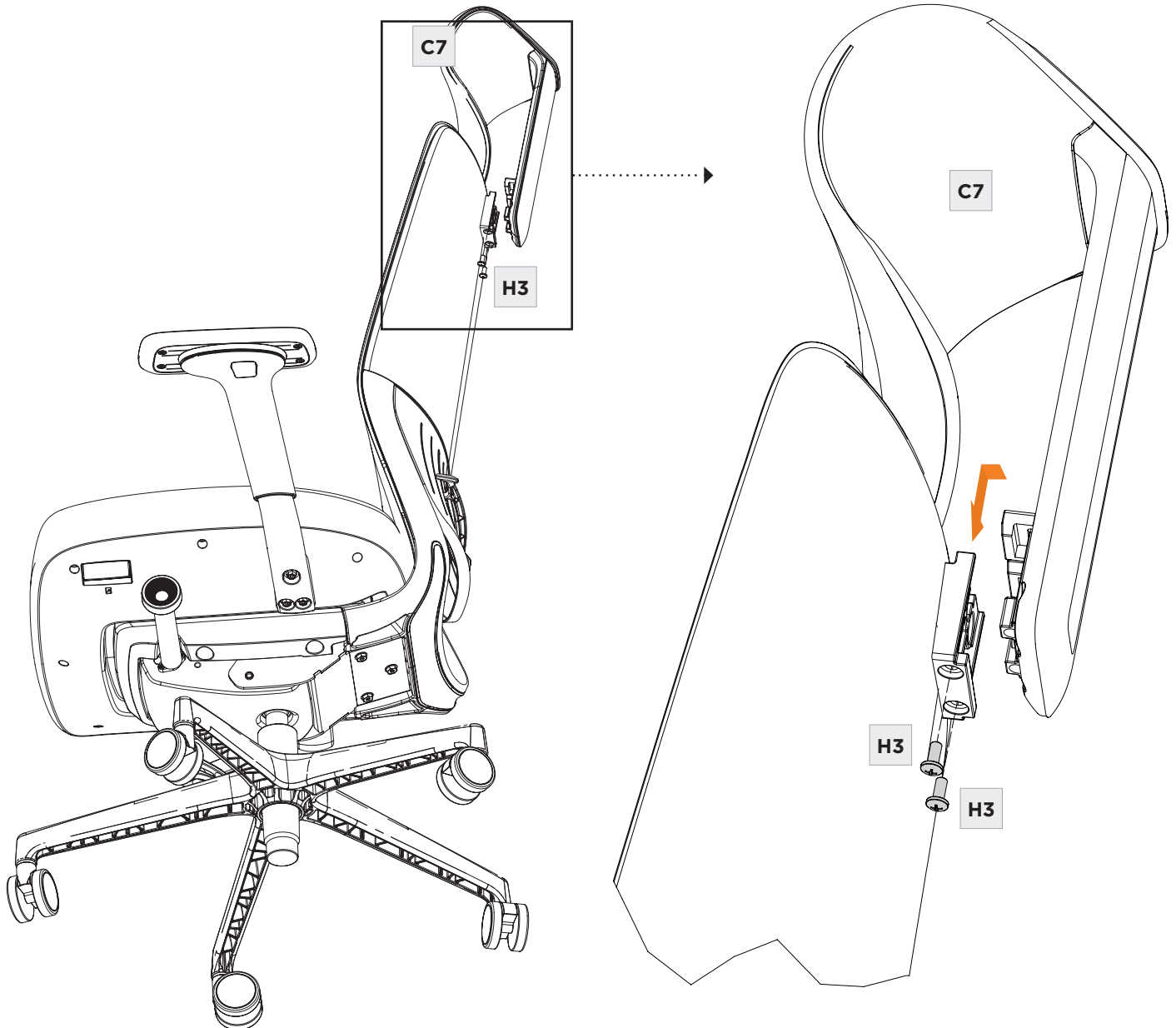

ADJUSTING ARMRESTS

Lift the button under the arm to adjust the height. Further, refine your settings by grasping the top of the arms and sliding in any direction. For optimal ergonomic positioning, elbows should stay close to your sides and your wrists should be straight.

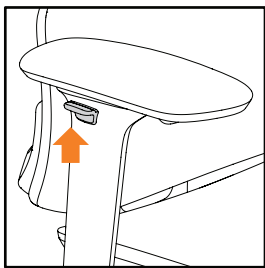

ADJUSTING HEADREST

To position the headrest, raise it completely to release it, then move it to its lowest position. As you slowly move it up, it will ratchet through various stopping heights. Select the best height for your comfort. To reposition, completely raise and lower the headrest to reset it and start the process again.

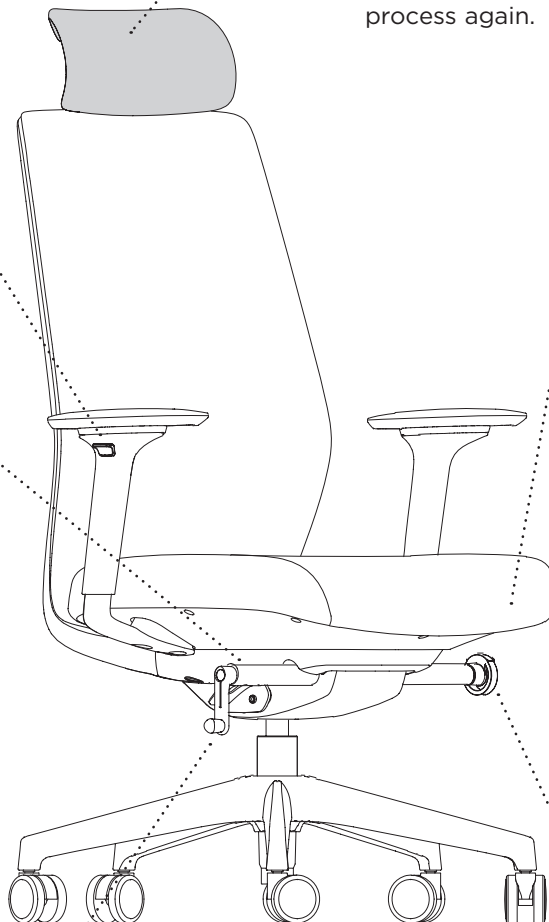

ADJUSTING SEAT DEPTH

To adjust the seat depth, lift the lever under the left side of the seat. Slide seat forward or back and release lever to lock it into position. Allow 2"-3" of space between the back of your knees and the edge of the seat.

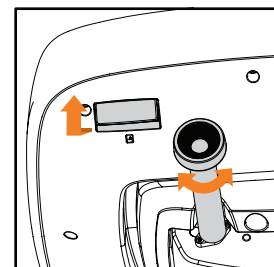

ADJUSTING SEAT HEIGHT

Height is adjusted using the lever on the right-hand control bar. Pull up on the lever while lifting or lowering your body weight in the chair; the seat will adjust on its pneumatic cylinder to reach your desired height.

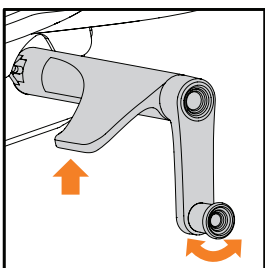

SYNCHRO TILT

Rotate the left control knob to lock and unlock the chair recline. Lean back to the desired position and turn the same knob to lock the back into one of four recline positions.

TILT TENSION CONTROL

Adjust the force needed to create a softer or firmer recline motion. Pull out the lever on the right-hand control bar and rotate it several times. Turn clockwise for more tension, counterclockwise for less tension.

WARRANTY

BDI warrants to the original purchaser that this product shall be free of defects in assembly, material, or workmanship for five (5) years from the original date of retail purchase. In the event of a proven defect in this product's assembly, material, or workmanship within five (5) years from the original date of purchase, BDI will replace any such defective part(s). This warranty coverage is based on an 8-hour shift by any user weighing up to 300 lbs. Claims under this limited warranty or any implied warranty shall be limited to replacing 100% of the chair at BDI's sole option and discretion.

This warranty does not apply to normal wear or damage from misuse, abuse, improper storage or handling, installation, accident, repair or alteration, or other circumstances not directly attributable to manufacturing or material defects.

To view BDI's complete warranty information, visit www.bdiusa.com/warranty

PRODUCT REGISTRATION

Registering your new BDI product allows us to send you important product updates, service information, and helpful hints related to your BDI products. Register today, and you will be entered to win free a BINK table from BDI: www.bdiusa.com/register

LAW LABEL

Reprinted here is the chair's law label, required for upholstered goods by some state jurisdictions.

<p>UNDER PENALTY OF LAW THIS TAG NOT TO BE REMOVED EXCEPT BY THE CONSUMER</p>	<p>NOTICE THIS ARTICLE MEETS THE FLAMMABILITY REQUIREMENTS OF CALIFORNIA BUREAU OF ELECTRONIC AND APPLIANCE REPAIR, HOME FURNISHINGS AND THERMAL INSULATION TECHNICAL BULLETIN 117- 2013. CARE SHOULD BE EXERCISED NEAR OPEN FLAMES OR WITH BURNING CIGARETTES.</p> <p>THE UPHOLSTERY MATERIALS IN THIS PRODUCT: <input type="checkbox"/> CONTAIN ADDED FLAME RETARDANT CHEMICALS <input checked="" type="checkbox"/> CONTAIN NO ADDED FLAME RETARDANT CHEMICALS</p> <p>The State of California has updated the flammability standard and determined that the fire safety requirements for this product can be met without adding flame retardant chemicals. The state has identified many flame retardant chemicals as being known to, or strongly suspected of, adversely impacting human health or development.</p>
<p>ALL NEW MATERIAL Consisting of 100% POLYURETHANE FOAM</p>	
<p>REGISTRY NO.: CA44482 (CN)</p>	
<p>Certification is made by the manufacturer that the materials in this article are described in accordance with law.</p>	
<p>MADE FOR: BDI</p> <p>14954 BOGLE DRIVE CHANTILLY, VIRGINIA 20151 USA</p>	
<p>MADE IN CHINA</p>	<p>COMPLIES WITH U.S. CPSC REQUIREMENTS FOR UPHOLSTERED FURNITURE FLAMMABILITY</p>



These distinctive product configurations are protected by US and international patents, trade dress, and/or copyright laws. Coda & BDI are trademarks of Becker Designed, Inc. All rights reserved. ©2023, BDI

Made in China.