

Slide **(E) Metal Leg** into **(F) Metal Rail** and attach by using **(B1) Hex Wrench** and **8 (D) Screws**.

NOTE: You **MUST** align arrows on **(F) Metal Rails** with arrows on **(E) Metal Legs** for proper orientation.

	PART/DESCRIPTION	QTY
	B1-HEX WRENCH	1
	D-SCREW	8

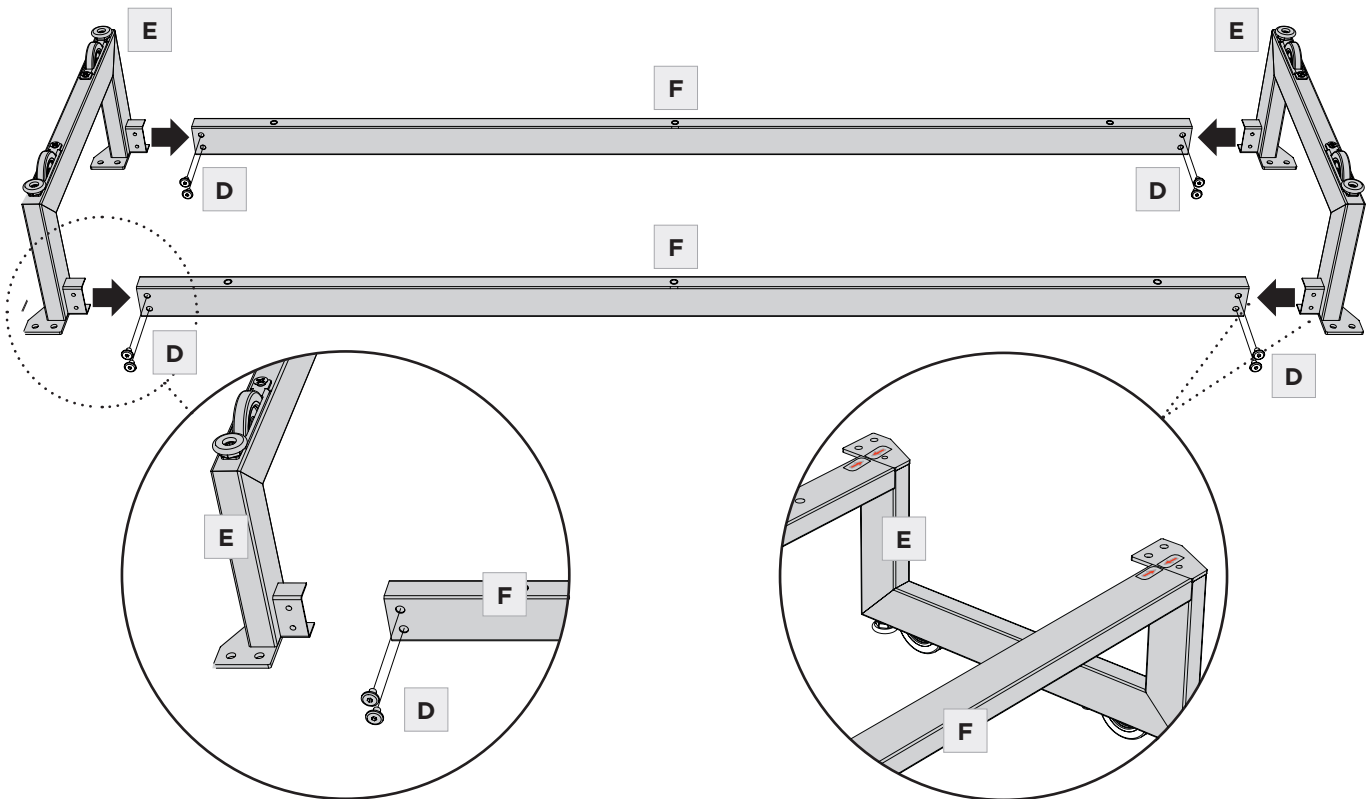

Removal of wheels (optional):

Detach **Wheel Assembly** from **(E) Metal Leg** by removing the **Leveler** and **Screw**.

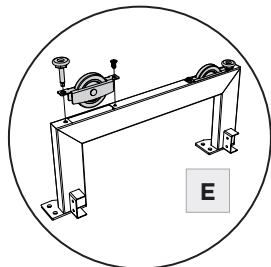

Reinstall **Leveler** to **(E) Metal Leg**.

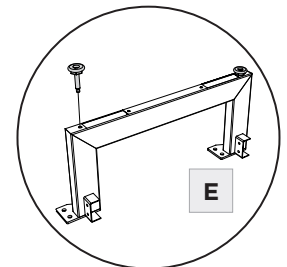



STEP 2. ATTACH THE BASE

ASSEMBLY

Carefully lay **(C) Cabinet** on its back. Using **(B1) Hex Wrench**, attach the base assembly to the bottom of the **(C) Cabinet** with **(D) Screws** and **(G) Screws**.

Note: Each of the metal legs has levelers that can be adjusted using the **(B2) Hex Wrench**.

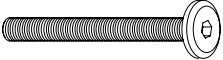
	PART/DESCRIPTION	QTY
	B1-HEX WRENCH	1
	D-SCREW	8
	G-SCREW	6

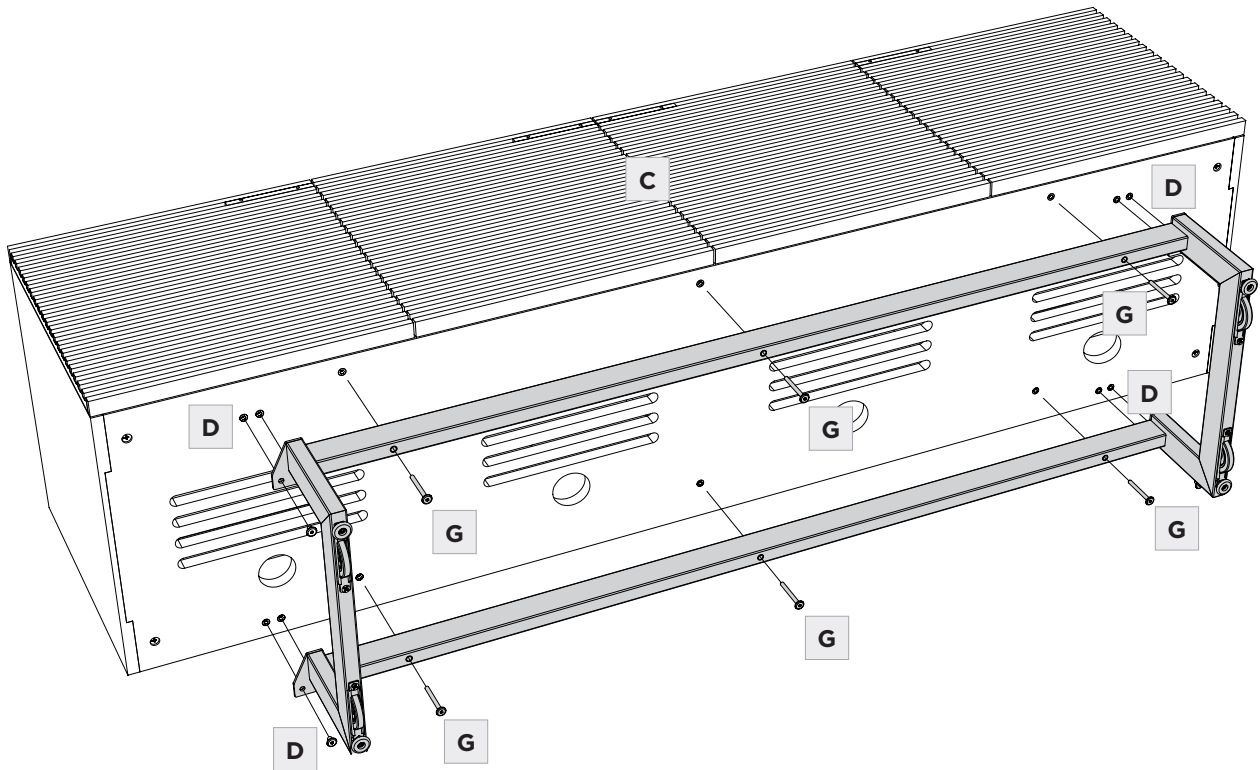

HANSEN
INTERIORS