

LINQ™ 9186

DRESSER

INSTRUCTION MANUAL

LET'S GET STARTED.

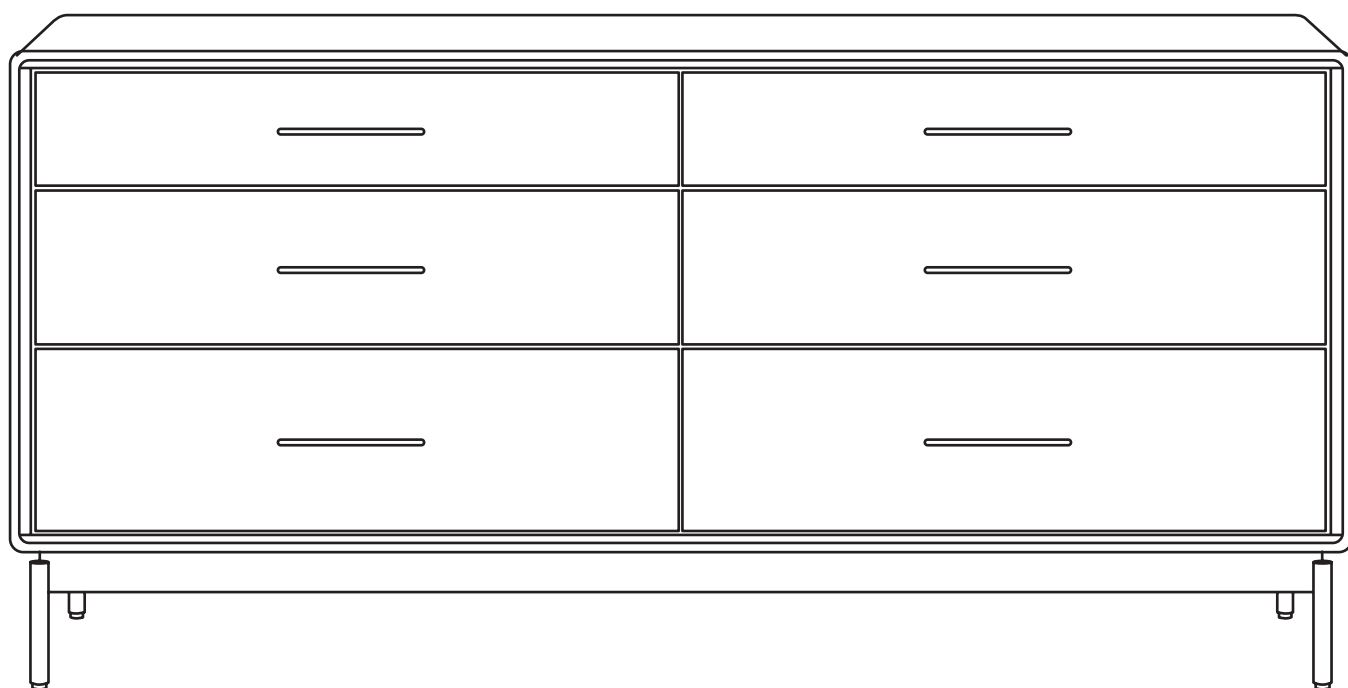

DESIGNED BY MATTHEW WEATHERLY

BDi

BDIUSA.COM

Congratulations on the purchase of your LINQ Dresser 9186 from BDI. Your dresser has been designed to provide a lifetime of enjoyment. This manual will provide assembly instructions and other helpful information to ensure you get the most out of your product. Please save it for future reference.

Your LINQ Dresser has been engineered for simple assembly. Please follow these directions carefully to prevent any damage.

Should you need further assistance, contact BDI at customerservice@bdiusa.com.

ENJOY!



HARDWARE AND COMPONENTS

Unpack and identify the parts listed below. The assembly workspace should be a non-marring surface, such as carpet. For missing hardware pieces, please contact BDI Customer Service at customerservice@bdiusa.com. For all other concerns, please contact your BDI retailer.

Do not use power tools for the assembly of this product.

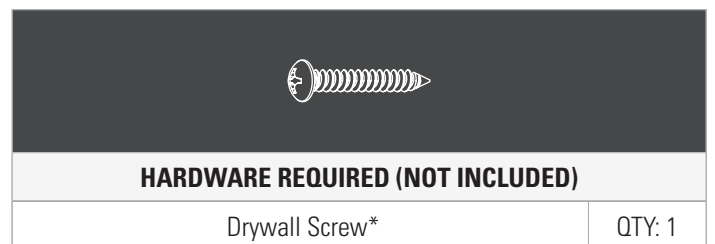
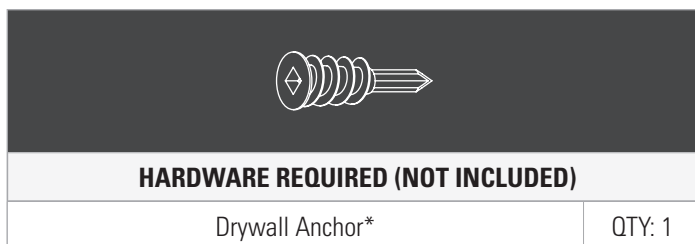
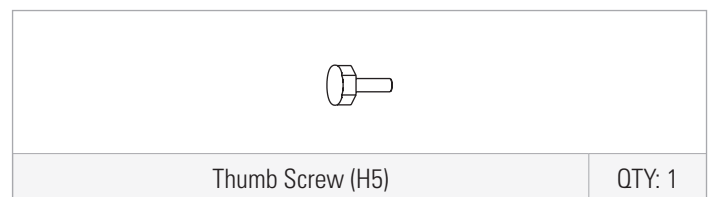
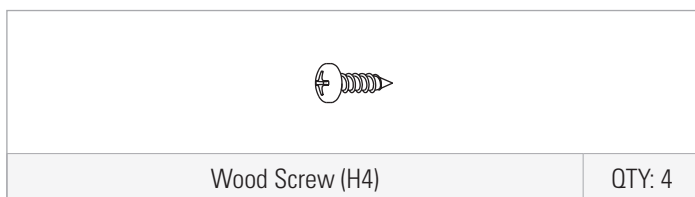
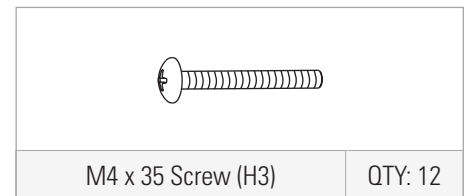
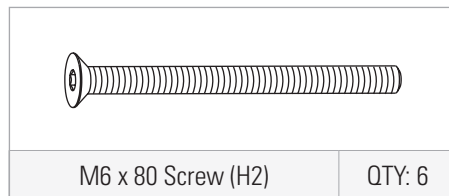
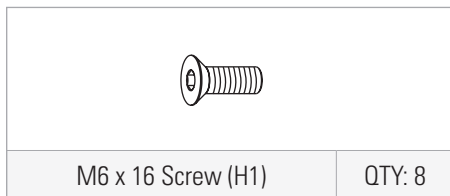
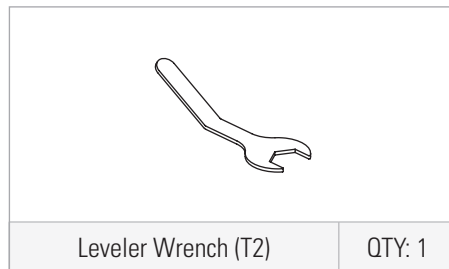
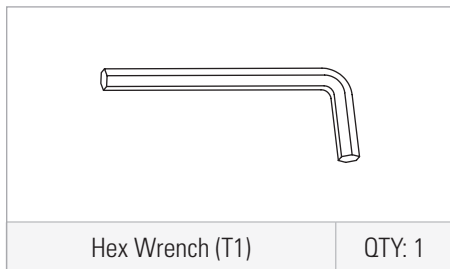

*Use appropriate wall anchor and screw.

HARDWARE AND COMPONENTS

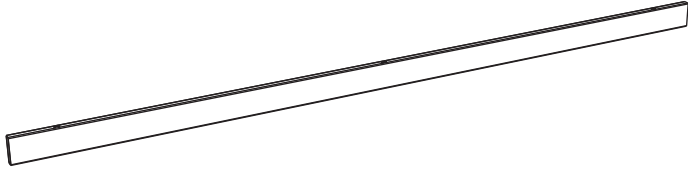

Spanner (C1)

QTY: 2

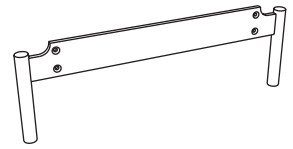

Leg (C2)

QTY: 2



Cabinet (C3)

QTY: 1



Drawer Pull (C4)

QTY: 6

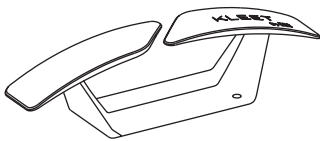

KLEET (C5)

QTY: 2



Anchor Strap (C6)

QTY: 1

STEP 1. ASSEMBLE BASE

ASSEMBLY

Lay the **Spanners (C1)** on a soft, non-marring surface, like carpet. Attach the **Legs (C2)** to the **Spanners (C1)** using **8 Screws (H1)** and tighten with **Hex Wrench (T1)**.

	HEX WRENCH – T1	QTY 1
	SCREW – H1	QTY 8

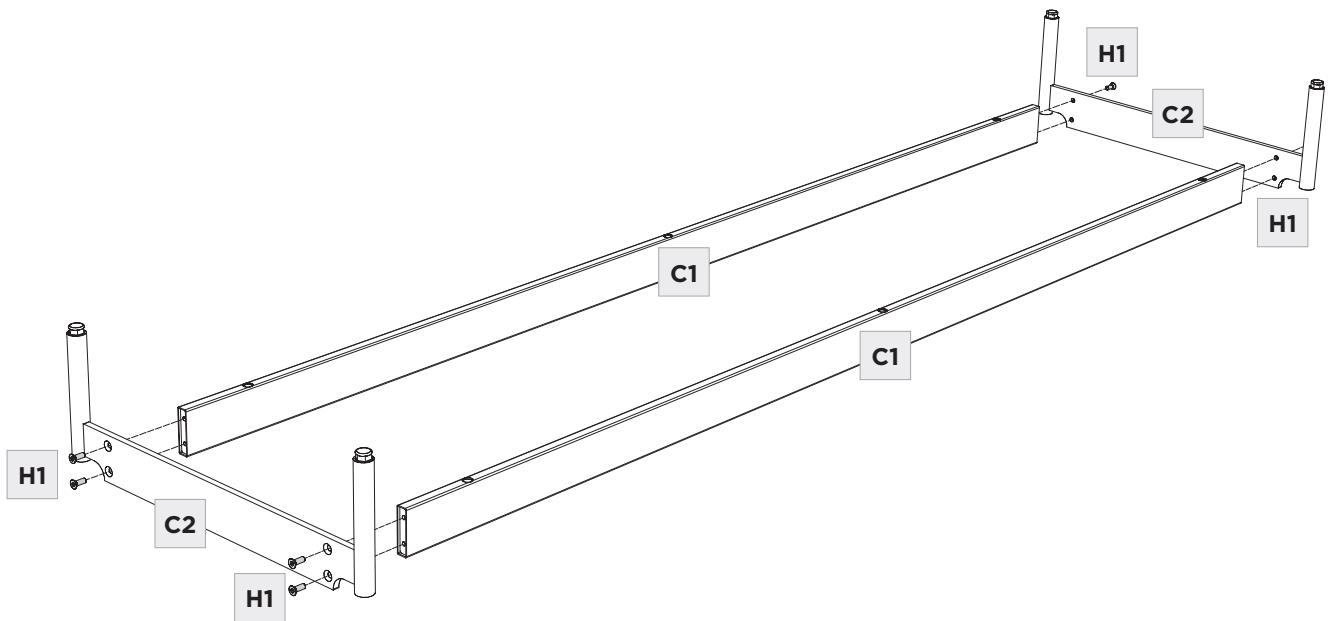



With help from another person, carefully position the **Cabinet (C3)** onto a layer of honeycomb packing material and orient it on its back as shown.

Position the **Base** as shown and attach with **6 Screws (H2)**. Tighten with **Hex Wrench (T1)**.

NOTE: The packing material creates finger space to lift the cabinet after attaching the base.

	HEX WRENCH – T1	QTY 1
	SCREW – H2	QTY 6

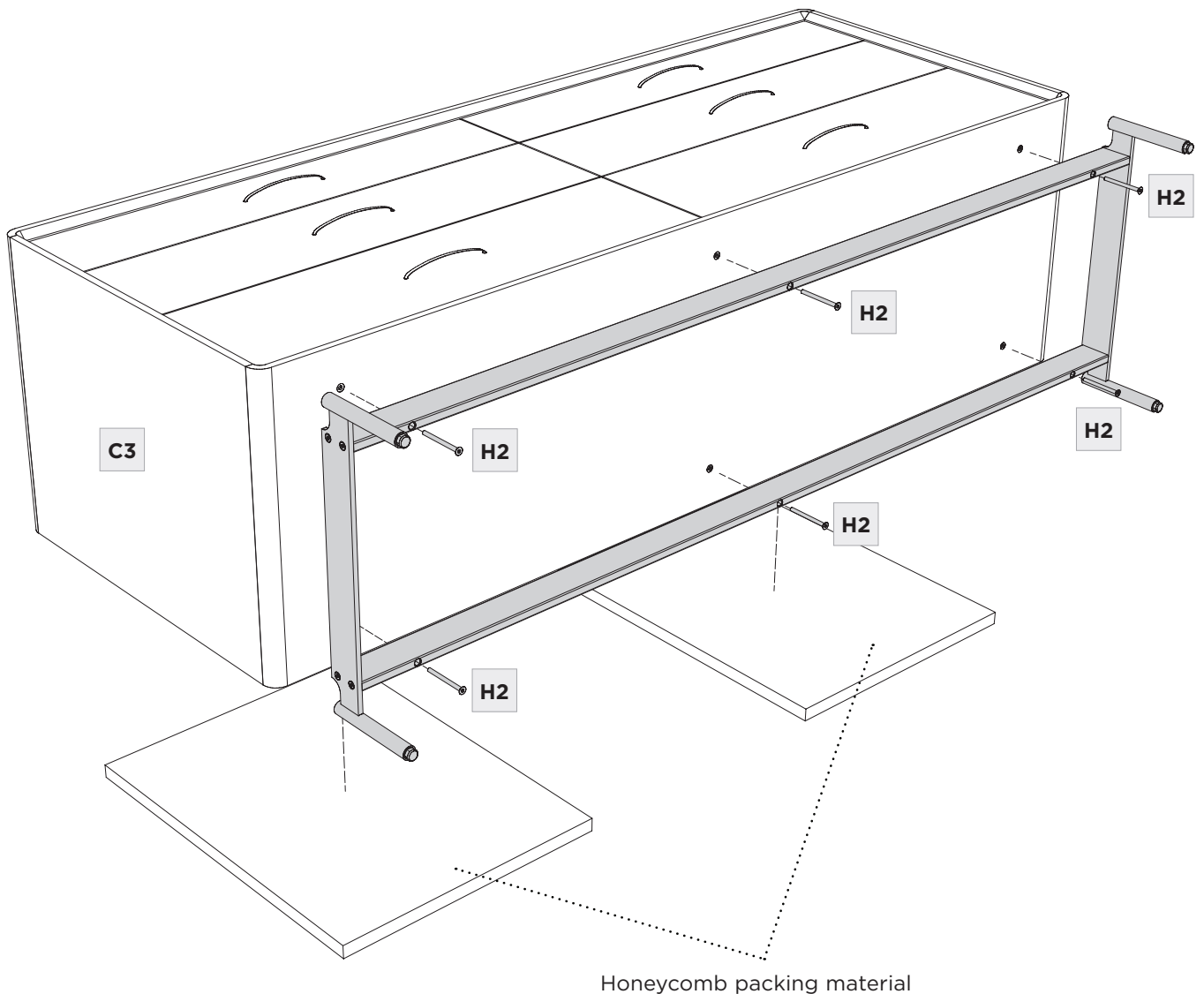



STEP 3. ATTACH DRAWER PULLS

ASSEMBLY

With the help of another person, carefully turn the Dresser onto its feet. **One row at a time**, open the drawers, cut the ribbon off the drawer, and install the **6 Drawer Pulls (C4)** using **12 Screws (H3)**. Tighten with **Phillips Head Screwdriver (not included)**.

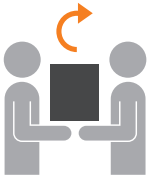

NOTE: Drawers have an interlocking mechanism to prevent multiple drawers in a single column from being opened simultaneously. This greatly reduces the risk of tip over.

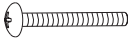

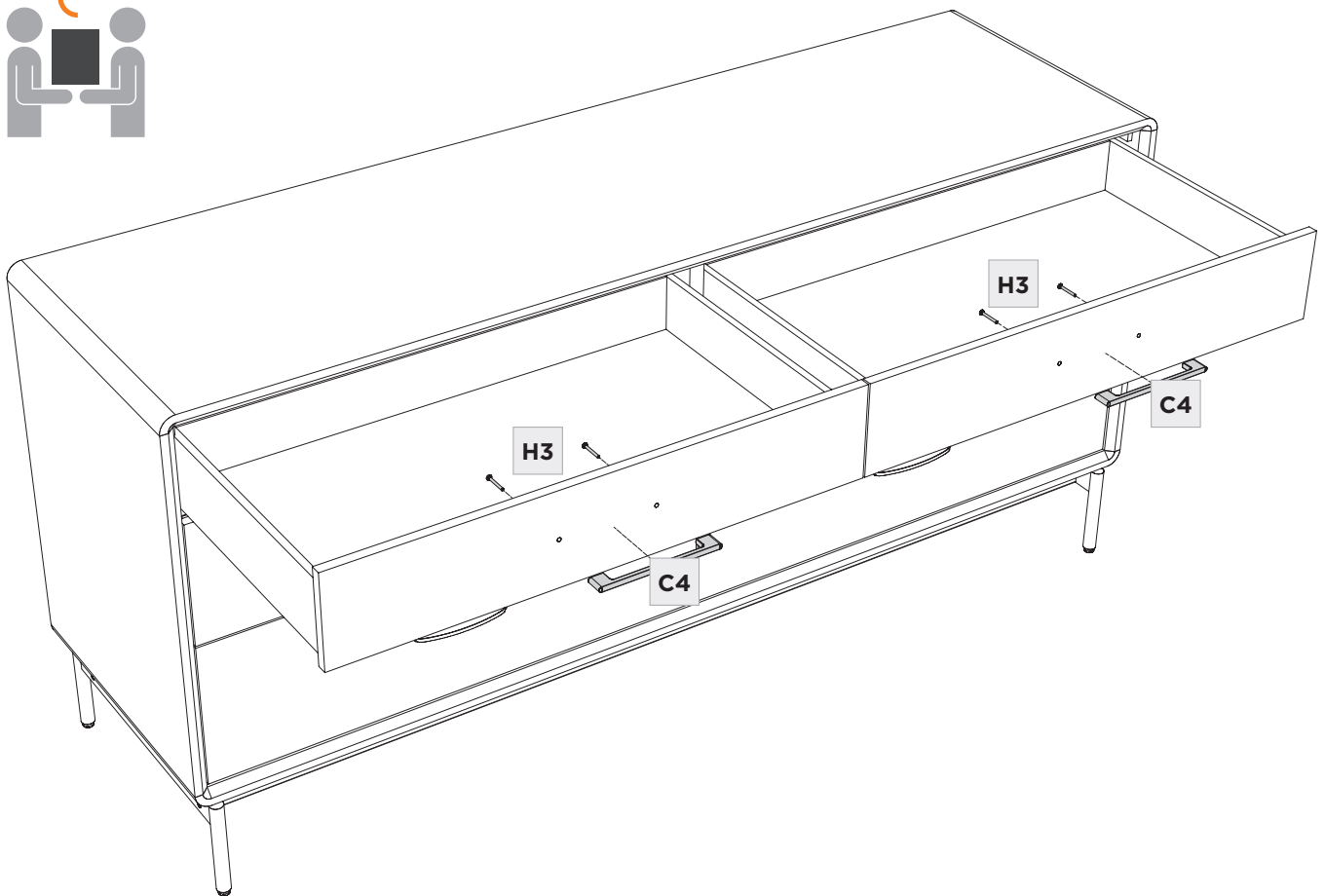
	NOT INCLUDED PHILLIPS SCREWDRIVER	QTY 1
	SCREW – H3	QTY 12



Install the **KLEETS (C5)** to the back of the **Cabinet** using **4 Wood Screws (H4)**. Tighten with **Phillips Head Screwdriver (not included)**.

	<p>NOT INCLUDED PHILLIPS SCREWDRIVER</p>	<p>QTY 1</p>
	<p>SCREW – H4</p>	<p>QTY 4</p>

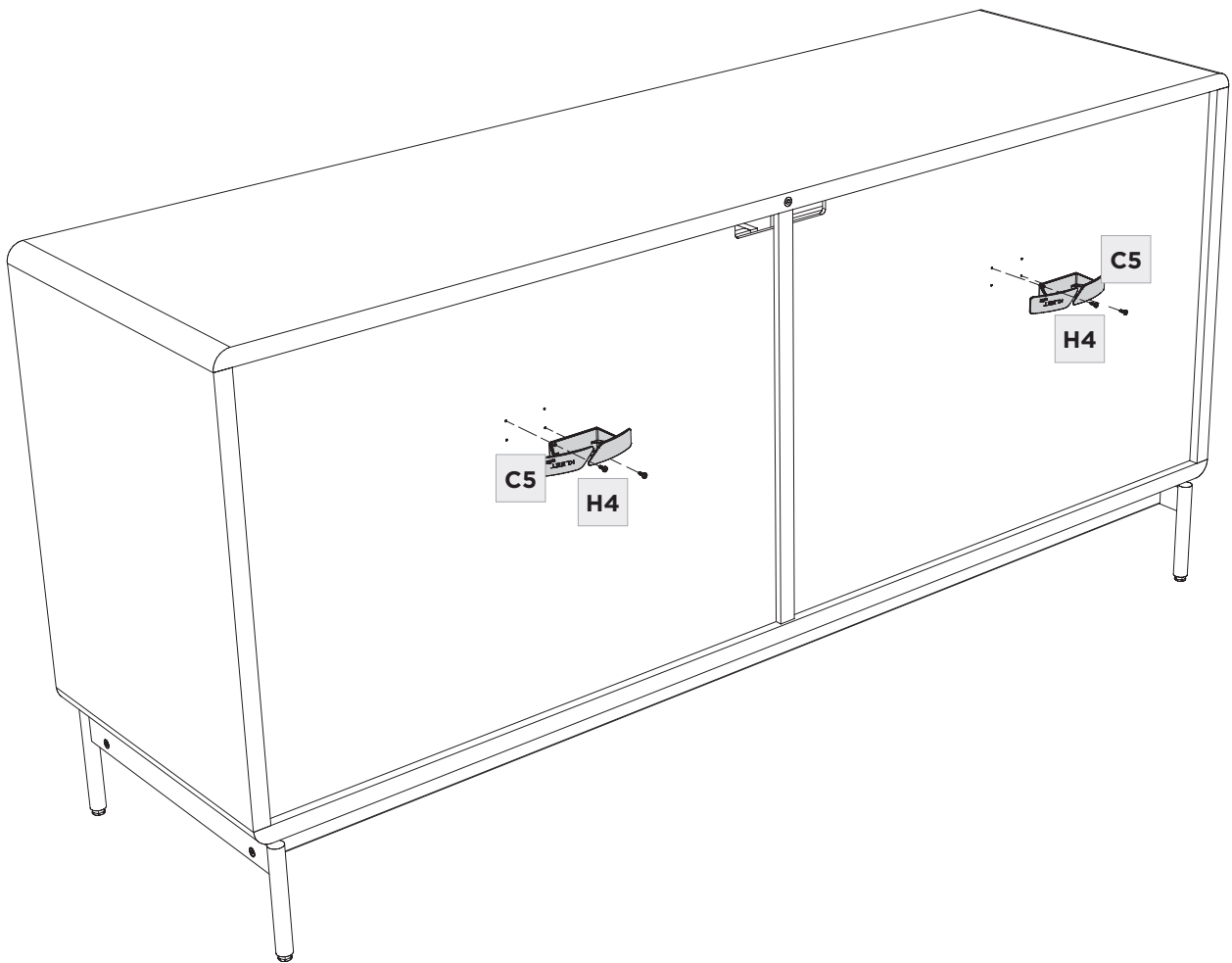

STEP 5. INSTALL ANCHOR STRAP & SECURE CABINET

2 PERSON TASK







ASSEMBLY

With help from another person, carefully walk the cabinet into the desired position against the wall.

It is strongly recommended that you anchor your LINQ Dresser to the wall using the provided **Anchor Strap (C6)**. Use painter's tape to mark the upper left corner of the unit, as shown.

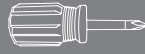
With help from another person, carefully move the cabinet away from the wall. Measure and mark the wall as shown.

Attach one end of the **Anchor Strap (C6)** to the wall at the marked location with an **appropriate wall anchor and screw (not included)**.

	NOT INCLUDED PHILLIPS SCREWDRIVER	QTY 1
	NOT INCLUDED WALL ANCHOR	QTY 1
	NOT INCLUDED SCREW	QTY 1
	THUMB SCREW – H5	QTY 1

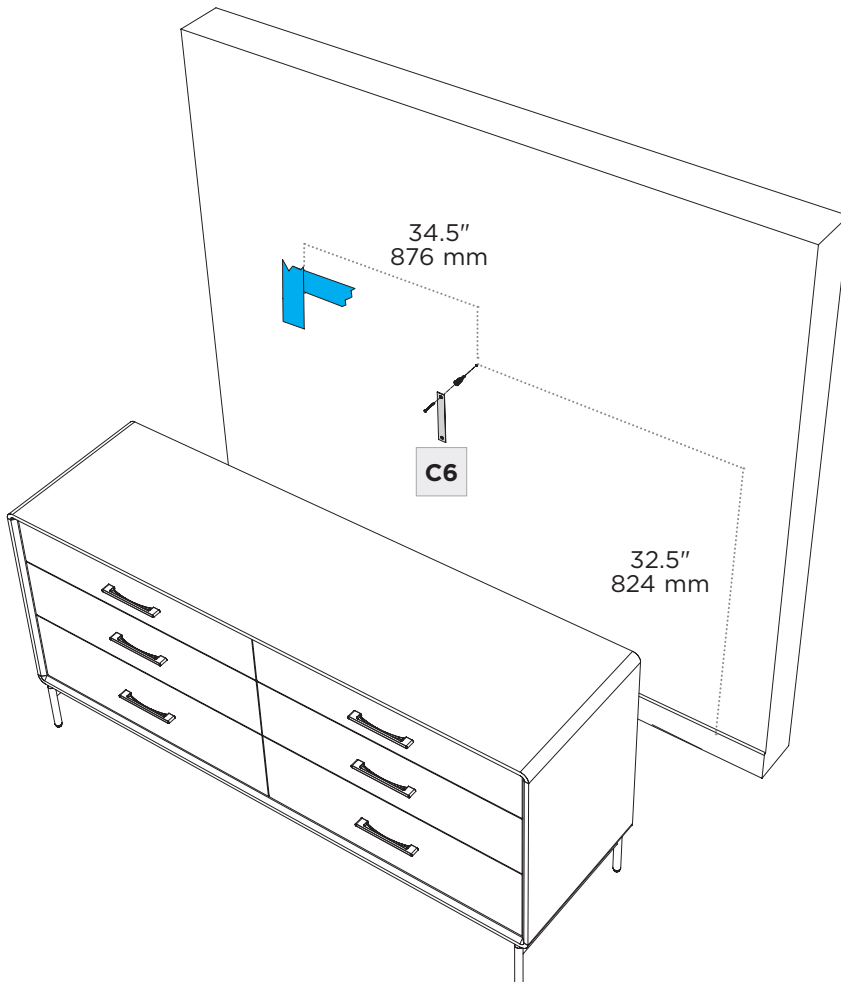

Carefully move your Dresser close to the wall and attach the loose end of the **Anchor Strap (C6)** to the back edge of the top panel with the **Thumb Screw (H5)**.

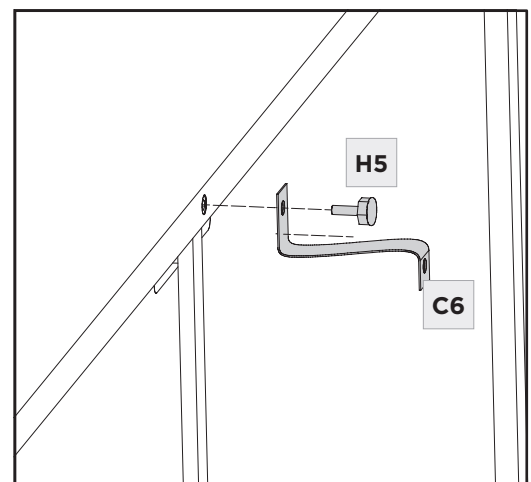

Once the unit is completely assembled and in its final position, adjust the levelers using **Leveler Wrench (T2)**. Using a level (not provided), level your cabinet first side to side and then front to back. If your cabinet is on carpeting, check your front to back level after loading the cabinet and opening the heaviest drawers. This will ensure the cabinet remains level during operation and reduce the risk of tip-over.

	PART/DESCRIPTION	QTY
	LEVELER WRENCH – T2	1

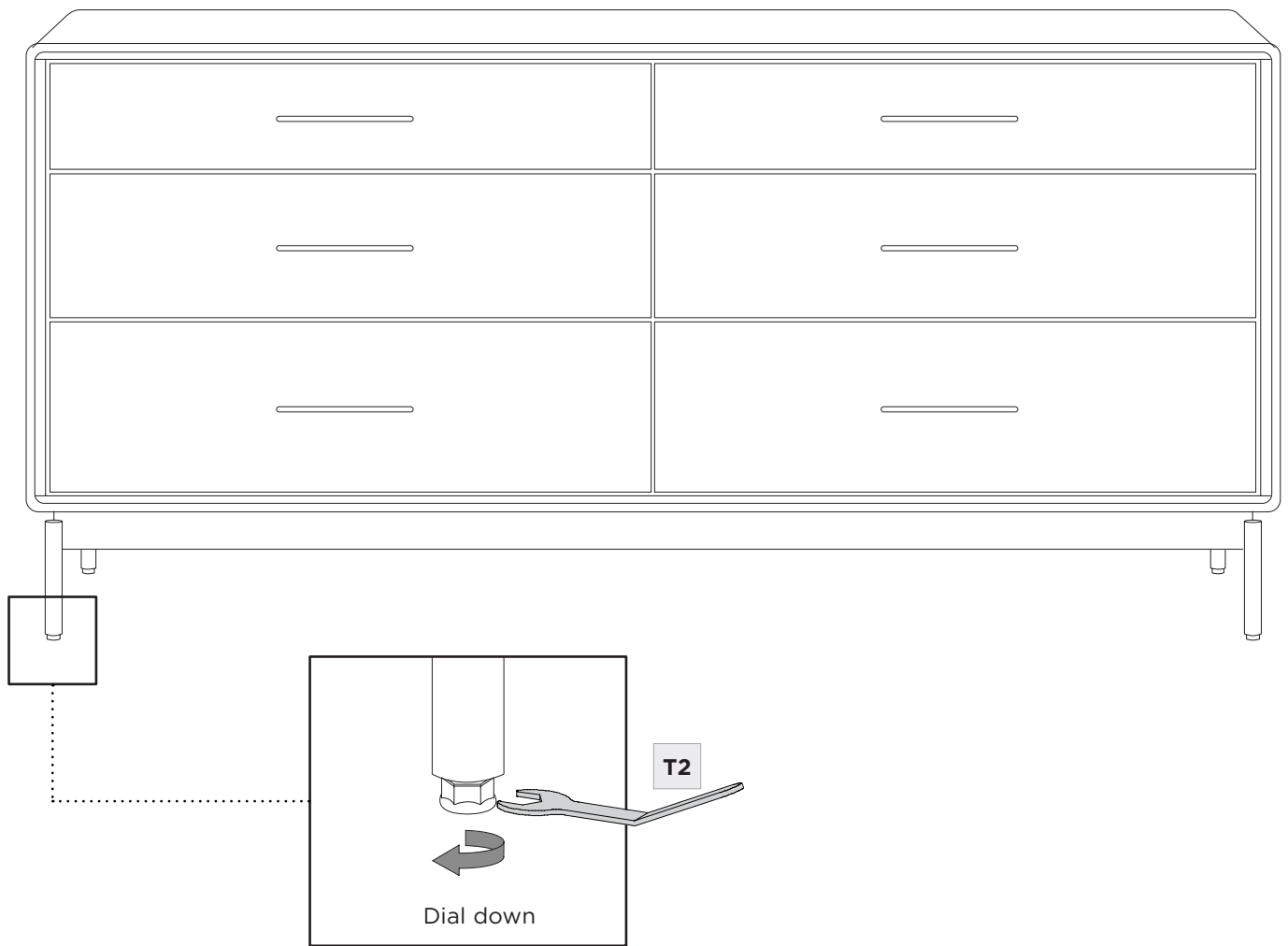

Your BDI furniture has been constructed with the finest materials, carefully manufactured, and designed to last a lifetime. Regular furniture care will prolong your enjoyment and keep it looking its best. Here are some general tips for taking care of BDI furniture. Your surfaces may vary.

GLASS

Glass surfaces are maintained using household glass cleaner and a paper towel or cloth.

SATIN-ETCHED GLASS

This uniquely smooth-to-the-touch glass surface can be regularly maintained using household glass cleaner and a paper towel or cloth.

A 'Magic Eraser' removes minor scratches or scuffs not eliminated using a paper towel or cloth. 'Magic Eraser' is a melamine foam product available at any grocery store or home improvement center. Dampen the entire glass surface and the Magic Eraser, then rub the whole surface in broad, even strokes using moderate pressure. Clean and dry the surface with a paper towel. Check for results and repeat as necessary. Any scratches or scuffing not eliminated by one of the above methods can often be addressed by 'refreshing' the glass. This process should not be required more than once per 6-12 months. See this brief video for the simple method: www.bdiusa.com/glass

WOOD

Wood surfaces should be cleaned with a slightly damp (not saturated) cloth or paper towel. Do not use glass cleaner on wood. If moisture remains, dry the surface with another cloth. If needed, a gentle, non-abrasive cleanser may be used, but wipe away all cleaner residue and dry the surface with a cloth.

BDI's wood finishes feature natural hardwood solids and veneers. Wood is a product of nature and—unlike man-made materials that can be manufactured to strict and consistent specifications—has natural imperfections that are part of its appeal and character. Every piece of wood differs from every other, even when coming from the very same tree. As such, grain, texture, and tone variation should be expected from one panel or piece of furniture to the next.

While BDI's stained wood finishes are stable in tone & appearance, all finishes are subject to some degree of discoloration with prolonged exposure to direct sunlight. Please avoid positioning your BDI cabinet in any area with ample direct sunlight. To learn more about the features of natural wood, visit www.bdiusa.com/wood

METAL, PORCELAIN, & PAINTED SURFACES

Surfaces should be cleaned with a slightly damp (not saturated) cloth or paper towel. If moisture remains, dry the surface with another cloth. If needed, a gentle, non-abrasive cleanser may be used, but be sure to wipe away all cleaner residue and dry the surface with a cloth.

WARRANTY

BDI warrants to the original purchaser that for the below-stated warranty term, BDI will repair or replace any product, part, or component covered by this warranty that fails under everyday use due to a defect in material or workmanship. BDI will repair or replace the product mentioned above, part, or component with a comparable product, part, or component. The decision to repair or replace will be at BDI's sole discretion.

BDI furniture is warranted for three (3) years from the date of purchase, as shown on your sales receipt. The warranty period starts from the date of purchase. This warranty extends only to the original purchasers who acquire new products from BDI Authorized Resellers. To be eligible for warranty coverage, any product, part, or component must have been assembled, installed, used, and maintained according to BDI's published instructions. Any modification to the original product voids the warranty.

To view BDI's complete warranty information, visit www.bdiusa.com/warranty

PRODUCT REGISTRATION

Registering your new BDI product allows us to send you important product updates, service information, and helpful hints related to your BDI products. Register today, and you will be entered to win free a BINK table from BDI: www.bdiusa.com/register



BDIUSA.COM

These distinctive product configurations are protected by US and international patents, trade dress, and/or copyright laws. LINQ & BDI are trademarks of Becker Designed, Inc. All rights reserved. ©2023, BDI | V.03.20.2023

Made in Vietnam.