

Instructions for Audrey Round Extension Tables

Unpack the table onto a soft level surface and identify the listed items.

Hardware included:

- ¼" - #20 x 35mm Allen bolts (4)
- Washers (4)
- 4mm Allen wrench (1)

Components included:

- Table top sub-assembly (1)
- Table leg base (1)

Audrey Round Extension Tables:

- 48" Round Extension Table
- 54" Round Extension Table

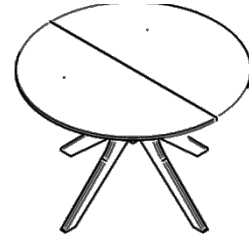

Tools required | Phillips head screw driver

Step 1: Remove the shipping blocks on the *table top assembly*

Lay the *table top sub-assembly* face down on a soft level surface. Use a Phillips head screw driver to remove *shipping blocks* under the *table top sub-assembly* by detaching all the 2" screws from the *shipping blocks* (**Figure 1**).

◇ **Figure 1.**
Remove the *shipping blocks* from the *table top sub-assembly*

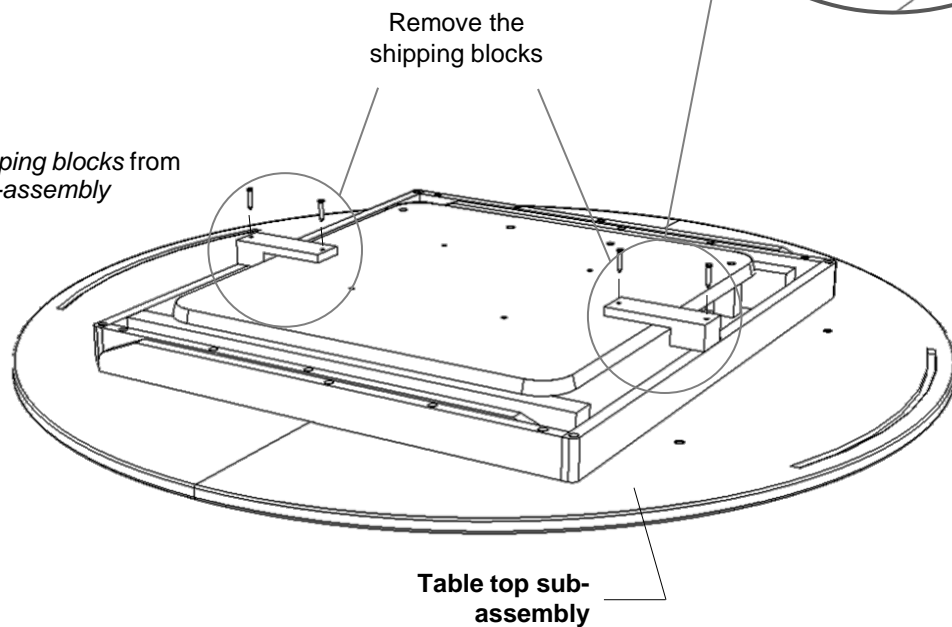

Step 2: Install *leg base*

As **Figure 2** shows, place the *leg base assembly* onto the bottom of the *table top assembly*. Align the holes on the *leg hub* to the pre-drilled holes on the bottom of the *table top*, then tighten the bolts and washers with provided Allen wrench. Carefully flip the table to its upright position.

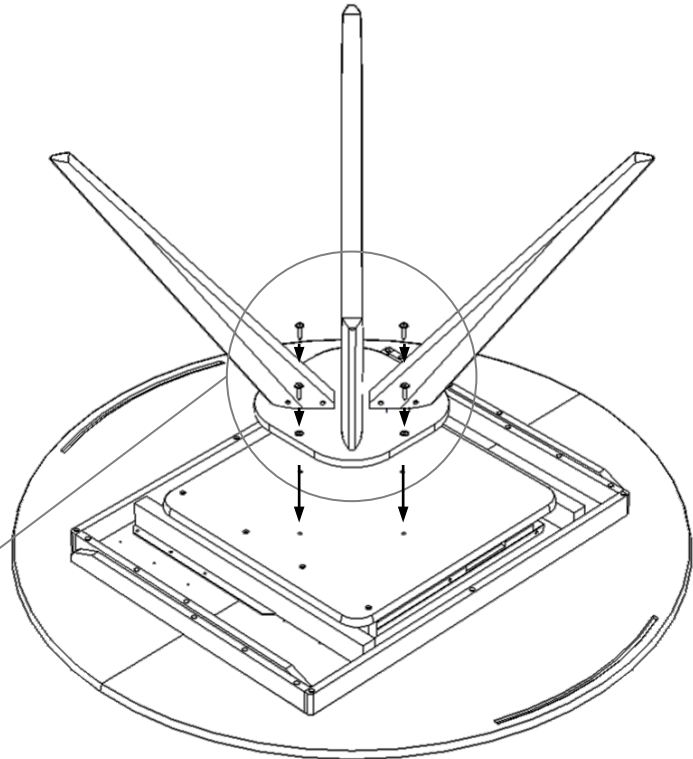
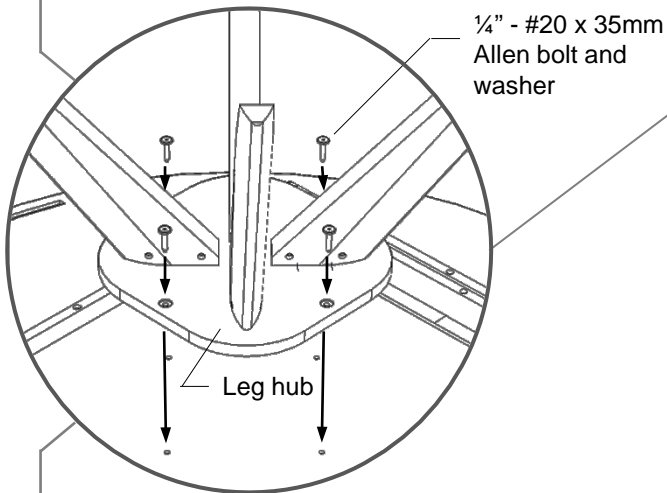

▷ **Figure 2.** Assemble the leg base

When
in use

How to use the Slide Lock to lock and unlock the table top

To lock the top, push down the small black handle on both end of the slide arm. To unlock the top, simply push the handle up on both sides. *Lock-up handle* located in the end of each side of the *slide arm* (**Figure 3**). If you prefer to use *Table Lock* to operate the table top, please keep this *Slide Lock* unlocked at all times after initial setup of the table.

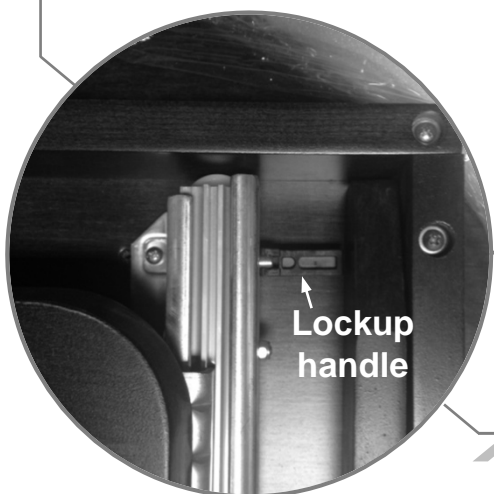

Slide arm

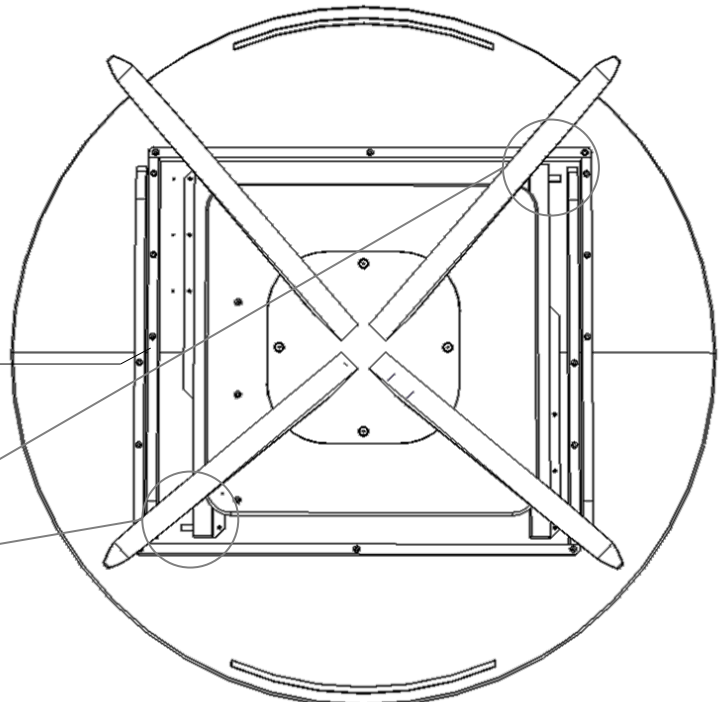

▷ **Figure 3.** Lockup handle location

Open the table top

- ▶ Unlock the table (if locked).
- ▶ Pull out the table top from either end.
- ▶ Unfold the leaf.
- ▶ Push the top from either end towards the center.
- ▶ Lock the table (optional).

Scan to watch
easystow operation video**Close** the table top

- ▶ Unlock the table (if locked).
- ▶ Pull out the table top from either end.
- ▶ Lift up the leaf and gently fold it into the table.
- ▶ Close the top by pushing it to the center from either end.
- ▶ Lock the table (optional).

Care Instructions

To care for and preserve the finish on your new Copeland Furniture piece, please keep the following recommendations in mind.

- While our furniture has been finished with a durable top coat, the surface may be sensitive to dents and abrasions during the first 30 days in your home.
- Treat the surface finish gently so it does not dent or chip. Tape or stickers should not be put on the finish.
- For general care use a soft cloth to dust the furniture.
- Use damp cloth with a mild soap to clean-up spills or dirt. Dry the surface thoroughly.
- Please do not use any polishes, waxes or solvents to clean the surface of the furniture. This holds true for new Copeland Furniture pieces as well as items you may already have in your home.
- Please do not place any candles directly on the surface of your furniture. The perfumes and dyes in the candles may penetrate the finish.
- Beds must be disassembled before moving to avoid damage. Never attempt to move the bed while it is assembled.

Special Care Instructions for Cherry Furniture

Please read the following if you have purchased a Copeland product in cherry. Furniture that has been crafted from cherry wood becomes darker with age. The change in color, from a reddish tan to a reddish brown, is most noticeable during the first six months of ownership. It is important to understand that exposure to light accelerates the natural oxidization process. An object left on a cherry wood surface for an extended period of time may retard the aging process in a limited area. Simply remove the object and, over time, the surface will attain a uniform reddish brown color.



How to Operate Extension Table Lock Mechanism



Tools required None

Locking locations

One leaf extension tables usually have two locking locations with a single locking handle (Figure 1). The inner position is for locking the table when the leaf is unfolded (Figure 1-2). The outer position is for locking the table when the leaf is folded (Figure 1-1). Two leaf extension tables have three locking locations. Similar to the one leaf table, the inner locking location is for when leaf is folded, the middle locking position is for when one leaf is open, the outer locking location is for when two leaves are open.

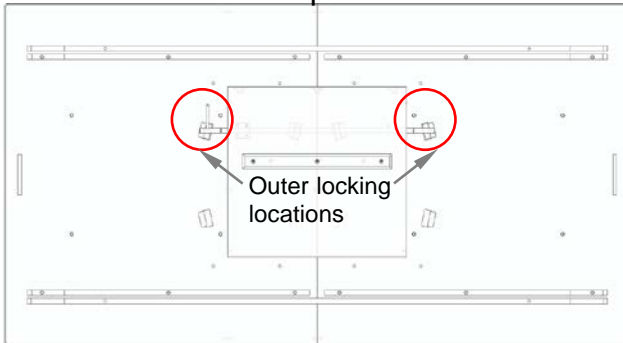

Figure 1-1. Outer locking position when leaf folded

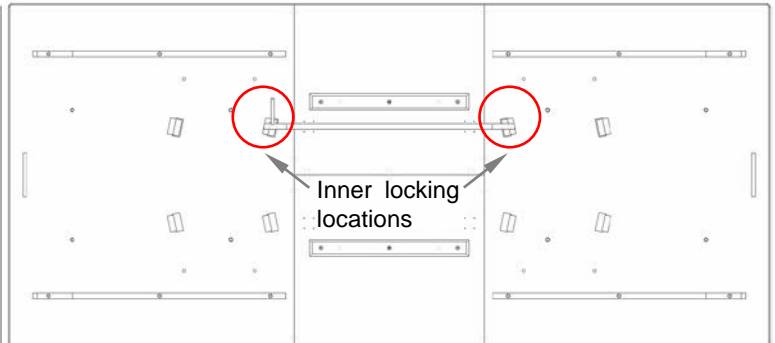

Figure 1-2. Inner locking position when leaf unfolded

How to lock/unlock the extension table

To release the lock, simply rotate the long handle (on the underside of the table) so that the short lock pin disengages from the friction plate (Figure 2-1).

To lock the table, rotate the long handle on the lock mechanism till the short lock pin engages with the friction plate (Figure 2-2).

Note: Seasonal changes could cause the table top to shrink and may affect lock pin engagement with the friction plates. If that happens, simply flip the friction plates that have the flat edge out. Flip them so that the serrated edge is facing out and the flat edge is in.

Figure 2-1. ▶
Unlock the table

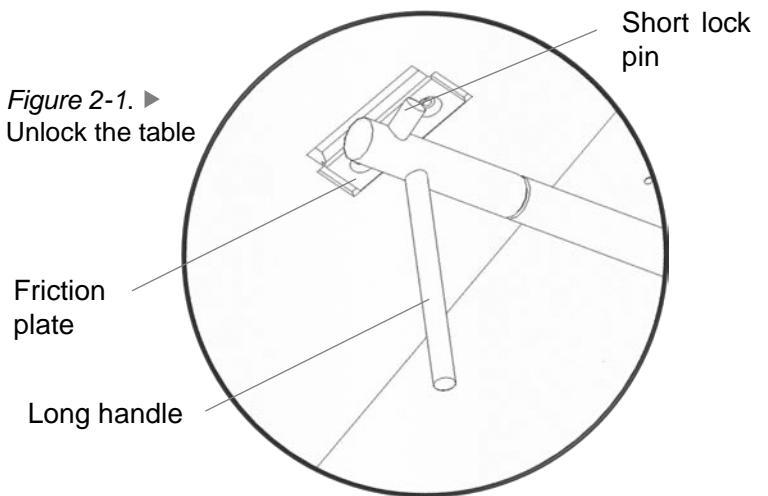

Figure 2-2. ▶
Lock the table

